

MITSUBISHI ELECTRIC AUTOMATION, INC

UNINTERRUPTIBLE POWER SUPPLY SYSTEM

9800A SERIES

OWNERS / TECHNICAL MANUAL

(For parallel operation possible model only.)

Revision 2.01 Feb. 4, 04
ALN-H0776

Preface

TABLE OF CONTENTS

LIST OF TABLES	iii
LIST OF FIGURES	iv
HOW TO USE THIS MANUAL	v
1.0 INTRODUCTION	1-1
1.1 GENERAL	1-3
1.2 DEFINITIONS	1-4
1.3 OPERATION OVERVIEW	1-5
1.4 SPECIFICATIONS	1-12
2.0 OPERATION CONTROLS AND INDICATORS	2-1
2.1 LED DISPLAY	2-2
2.2 EPO BUTTON	2-2
2.3 LIQUID CRYSTAL DISPLAY	2-3
2.4 EXTERNAL SIGNAL TERMINAL BLOCK	2-8
2.5 EXTERNAL COMMUNICATION CONNECTOR	2-12
3.0 INSTALLATION AND OPERATION	3-1
3.1 TRANSPORTATION AND INSTALLATION	3-1
3.2 INSTALLATION PROCEDURE	3-1
3.3 PROCEDURE FOR CABLE CONNECTIONS	3-2
3.4 OPERATING PROCEDURES	3-24
4.0 RESPONSE TO UPS FAILURE	4-1
5.0 PARTS REPLACEMENT	5-1
6.0 FAULT CODES	6-1
7.0 WARRANTY & OUT OF WARRANTY SERVICE	7-1

List of Tables

Table 1.1	Power Specifications	1-12
Table 1.2	UPS Module Information.....	1-12
Table 1.3	Detail of Specifications	1-13
Table 1.4	Rating of Contactor and Fuses	1-14
Table 3.1	How to Transport and Install the System	3-1
Table 3.2	List of UPS Weights (lb.).....	3-1
Table 3.3	Maximum Permitted Fault Current.....	3-2
Table 3.4	Recommended Cable Sizes	3-5
Table 3.5	Crimp Type Compression Lug	3-6

List of Figures

Figure 1.1	Single Line Diagram-Normal Operation	1-5
Figure 1.2	Single Line Diagram-Bypass Operation	1-6
Figure 1.3	Single Line Diagram-Battery Operation	1-7
Figure 1.4	UPS Parts Location	1-8
Figure 1.5	UPS Parts Location (Continued).....	1-10
Figure 1.6	External I/F circuit PCB IOAU-04	1-10
Figure 2.1	Operation/Display Panel	2-1
Figure 2.2	Main Screen	2-3
Figure 2.3	Start/Stop Screen	2-4
Figure 2.4	PIN Protection Screen	2-4
Figure 2.5	Bypass Voltage Abnormal Message Screen.....	2-4
Figure 2.6	Measurement Screen	2-4
Figure 2.7	Setup Screen.....	2-5
Figure 2.8	Log Select Screen	2-5
Figure 2.9	Event Log Screen	2-5
Figure 2.10	Battery Log Screen	2-6
Figure 2.11	Main Screen (Battery Operation)	2-6
Figure 2.12	Measurement Screen (Battery Operation)	2-6
Figure 2.13	Main Screen (Fault Indication)	2-7
Figure 2.14	Message Screen	2-7
Figure 2.15	External Signal Terminal Block.....	2-8
Figure 2.16	Control Wiring for External Contacts	2-10
Figure 2.17	Remote "Start" Contact Connections.....	2-11
Figure 2.18	External communication connector.....	2-12
Figure 3.1	UPS Terminal Designation	3-6
Figure 3.2	Diagram of input/output bus bars and terminal blocks	3-7
Figure 3.3	Diagram of Rectifier Cabinet & Inverter Cabinet Inter-connect	3-19
Figure 3.4	Diagram of Power and Control Wire Connect (Parallel Connection)	3-21
Figure 3.5	Operation Procedures: Start Up/Shut Down Procedure.....	3-24

How to use this Manual

This manual is designed for ease of use, giving the user easy and quick reference to information.

This manual uses notice icons to draw attention to the user important information regarding the safe operation and installation of the UPS. The notice icons used in this manual are explained below, and should be taken into account and adhered to whenever they appear in the text of this manual.



Warning: A warning notice icon conveys information provided to protect the user and service personnel against hazards and/or possible equipment damage.



Caution: A caution notice icon conveys information provided to protect the user and service personnel against possible equipment damage.



Note: A Note notice icon indicates when the user should make a reference of information regarding the UPS operation, load status and display status. Such information is essential if Mitsubishi field service group assistance and correspondence is required.

Safety Recommendations: If any problems are encountered while following this manual, Mitsubishi field service group assistance and correspondence is recommended.

1.0 INTRODUCTION

Your Mitsubishi Uninterruptible Power System (UPS) is designed to provide many years of reliable protection from power failure, brown-outs, line noise, and voltage transients. To ensure optimum performance of the equipment, follow the manufacturer's instructions. This manual contains descriptions required to operate the UPS. Please read this manual carefully and retain it for future reference.

**IMPORTANT SAFETY INSTRUCTIONS
RETAIN THESE INSTRUCTIONS**



This manual contains important instructions for the 9800A SERIES Uninterruptible Power Supply Systems that should be followed during installation and maintenance of the UPS and batteries.

WARNING 1



Lethal voltages exist within the equipment during operation. Observe all warning and cautions in this manual. Failure to comply may result in serious injury or death. Obtain qualified service for this equipment as instructed.

WARNING 2



This UPS does not include a Bypass input circuit breaker (MCCB) to protect bypass circuit. The Bypass input circuit breaker (MCCB) is to be field supplied and installed. Recommended Breaker (MCCB)'s Specifications are as follows:

Capacity (kVA)	Bypass Voltage (Vac)	Bypass Rating (Aac)	Breaker (A)
100	480	120	150
	600	96	125
150	480	180	225
	600	144	200
225	480	271	350
	600	217	275
300	480	361	500
	600	289	400
375	480	451	600
	600	361	500
500	480	601	800
	600	481	600
750	480	902	1200
	600	722	900

AC input and AC output overcurrent protection and disconnect devices shall be field supplied and installed. The DC output MCCB shall be field supplied and installed. The overcurrent protection device should be installed in the Battery cabinet and rated as indicated in TABLE 1.4.

1.1 GENERAL

The Mitsubishi 9800A SERIES UPS is designed to provide continuous and clean electrical power to a critical load. Additionally the UPS monitors power conditions affecting the load. In the event of an input power failure, the UPS will supply power to the critical load for the specified battery time.

If the input power is not restored promptly, back up power from the UPS battery permits the orderly shutdown of equipment supported by the UPS. The UPS is simple to start-up, operate and maintain.

The 9800A SERIES UPS is available in seven kVA sizes-100, 150, 225, 300, 375, 500 and 750kVA. Specifications for each kVA model appear in Section 1.4. The principles of operation described herein are applicable to all models.

This manual provides an overview of the 9800A SERIES components and their functions. The appearance and purpose of operator controls and indicators is described with procedures for operation, start-up, shutdown and basic maintenance included.

1.2 Definitions

UNINTERRUPTIBLE POWER SUPPLY SYSTEM (UPS) - All components within the UPS Module Cabinet and associated batteries that function as a system to provide continuous, conditioned AC power to a load. This is sometimes referred to as the "System".

UPS MODULE CABINET - The metal enclosure which contains the Rectifier, the Inverter, the Chopper, the Static Transfer Switch, the Internal Bypass line, the operator controls, and the internal control system required to provide specified AC power to a load.

UPS MODULE - The Rectifier and Inverter assemblies which, under the direction of the internal control system and operator controls, provide specified AC power to a load.

RECTIFIER - The UPS components which contain the equipment and controls necessary to convert input AC power to regulated DC power required for battery charging and for supplying power to the Inverter.

INVERTER - The UPS components which contain the equipment and controls necessary to convert DC power from the Rectifier, or the battery, to AC power required by the critical load.

CHOPPER - The UPS components which contain the equipment and controls necessary to charge the battery and supply power to the Inverter from battery.

STATIC TRANSFER SWITCH - The device which connects the critical load to the bypass line when the UPS module cannot supply continuous power.

BYPASS LINE - The line which conducts electricity directly from the input power source to the critical load during Maintenance or whenever the UPS is not completely operational.

INPUT POWER - Power provided by the electrical utility company, or auxiliary generator, which is connected to the UPS for supplying the critical load.

1.3 Overview

The UPS provides two power paths between the utility source and the critical load.

Figure 1.1 shows the path for normal operation, with the load powered from the inverter.

Figure 1.2 shows the path for bypass operation, with the load supplied through the static bypass line.

A) Normal operation: Load power supplied by each system UPS inverter.

Figure 1.1 Single Line Diagram - Normal Operation: Load powered by UPS inverters

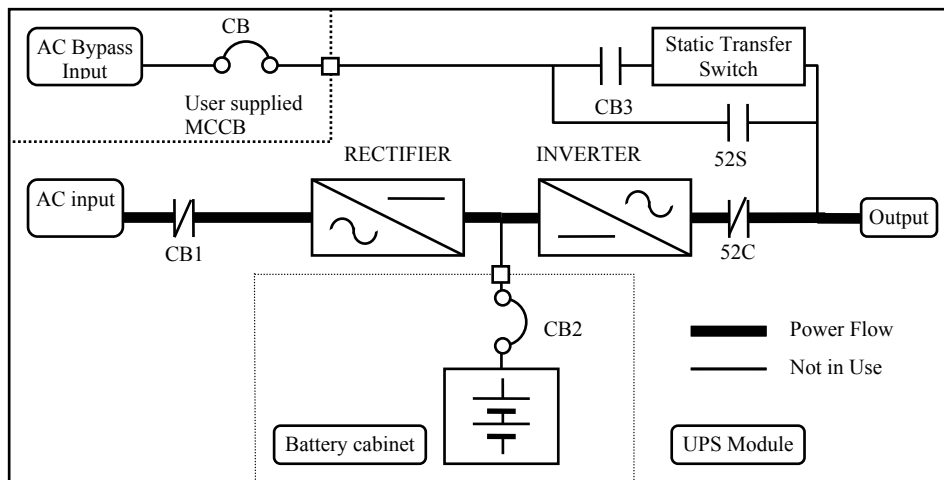

During normal operation, the path through the UPS inverters is used to power the load.

Referring to Figure 1.1: For each system UPS, the Input AC power is converted to DC by the Rectifier. DC power is utilized to charge the UPS battery and to provide power to the Inverter. The Inverter converts the DC power to clean AC power to supply the critical load.

The conversion - inversion process eliminates any voltage transients or fluctuations existing in the input power before it reaches the critical load.

The power drawn by the critical load is equally shared between all system UPS.

In the event of a UPS module failure, the critical load power will be continually supplied and shared by all other system UPS.

In the event of a load overcurrent, all system UPS will transfer to bypass without interruption to the critical load.



The Bypass Input circuit breaker (MCCB) for protection of the UPS and cables are field supplied and field installed. (See WARNING 2 on page 1-2)

B) Bypass Operation: Load Power supplied through each system UPS internal static bypass line.

FIGURE 1.2 Single Line Diagram - Bypass Operation: Load fed through Internal static bypass line.

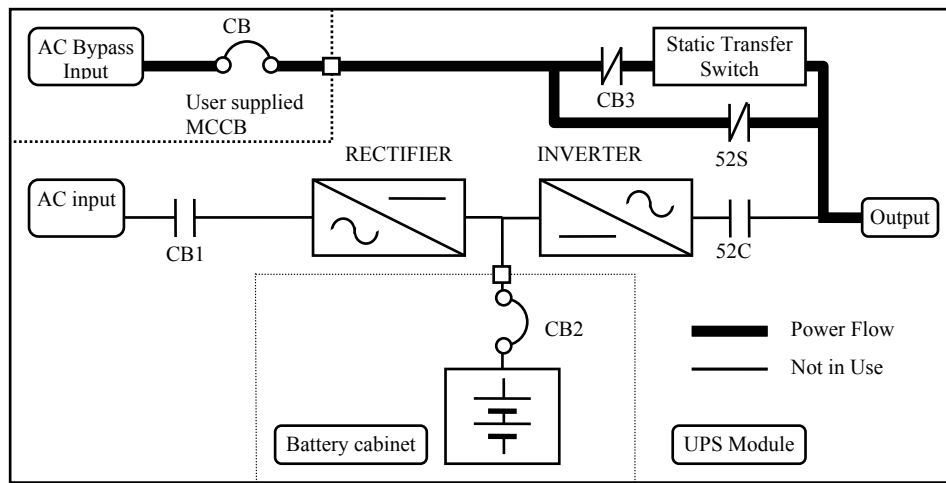

Referring to Figure 1.2: The Internal Static Bypass line is a Hard wired line through CB3 and contactor 52S which supplies the critical load with unconditioned input power.

Each system UPS internal static bypass line will equally share the power supplied to the critical load.

The internal static bypass line will route power to the critical load while the UPS module is de-energized during Start-up and before the system is fully operational.

Bypass operation will occur In the event of a load overcurrent, with all system UPS transferring to bypass without interruption to the critical load.

The internal control system determines the operation of the two paths, with the load powered from the inverter being the normal operation.

C) Battery operation: Load Power supplied by each system UPS battery and inverter.

FIGURE 1.3 Single Line Diagram - Battery Operation

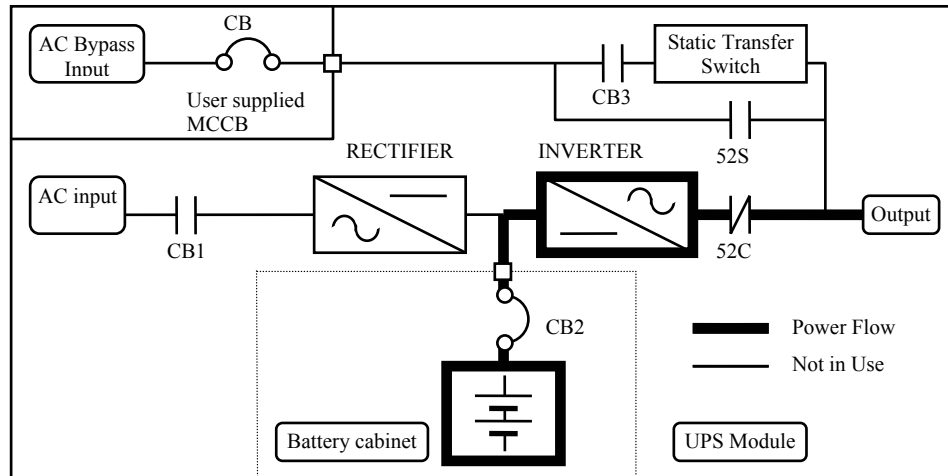

Referring to Figure 1.3: In the event of AC input source failure or interruption, each system UPS rectifier will de-energize and each UPS battery will immediately discharge and supply DC power to the Inverter to maintain continuous AC power to the load. This operation will continue until:

- a) The battery capacity expires and the inverter turns off, or
- b) Input power is restored after which the rectifier will power the inverter and critical load and simultaneously recharge the batteries.

A fully charged battery will provide power for the specified time at the rated load, or longer, at a reduced load.

When power is restored after a low battery shutdown, each system UPS Rectifier automatically restarts operation, recharges the batteries and the Inverter is automatically restarted without operator intervention. Load is automatically assumed by the inverter without operator intervention.

The power drawn by the load is equally shared between all system UPS during battery operation.

FIGURE 1.4-a UPS Parts Location (100kVA, 150kVA, 225kVA)

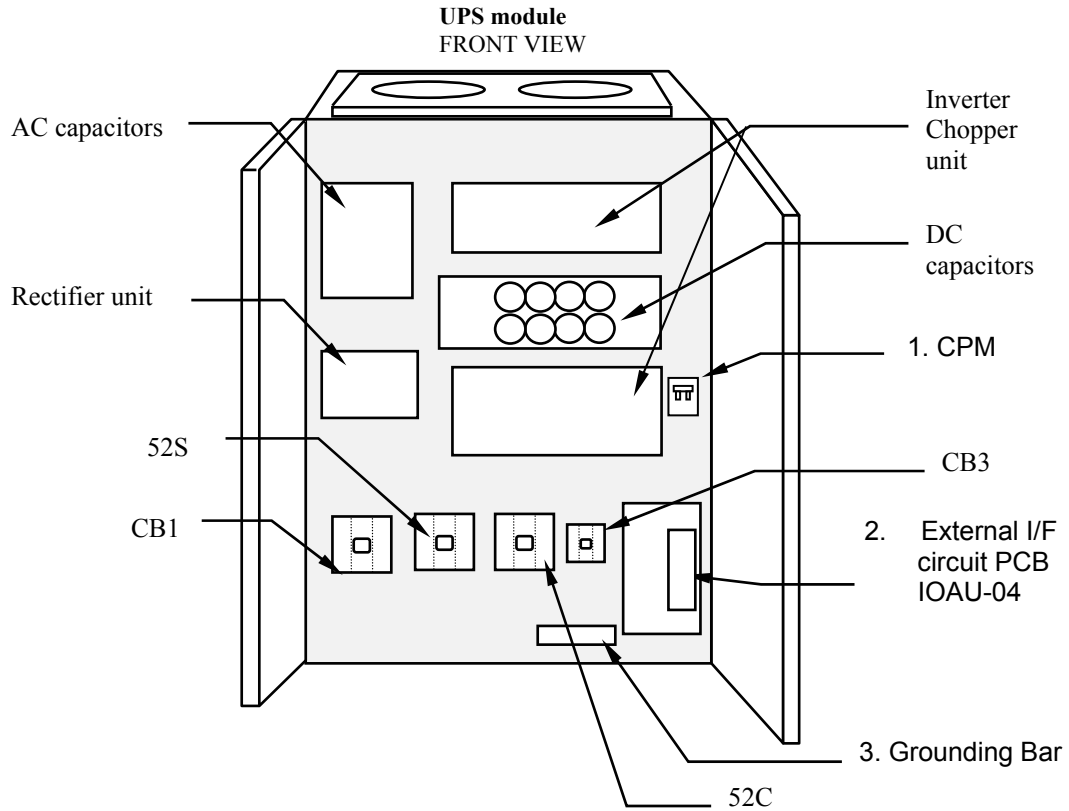

FIGURE 1.4-b UPS Parts Location (300kVA,375kVA)

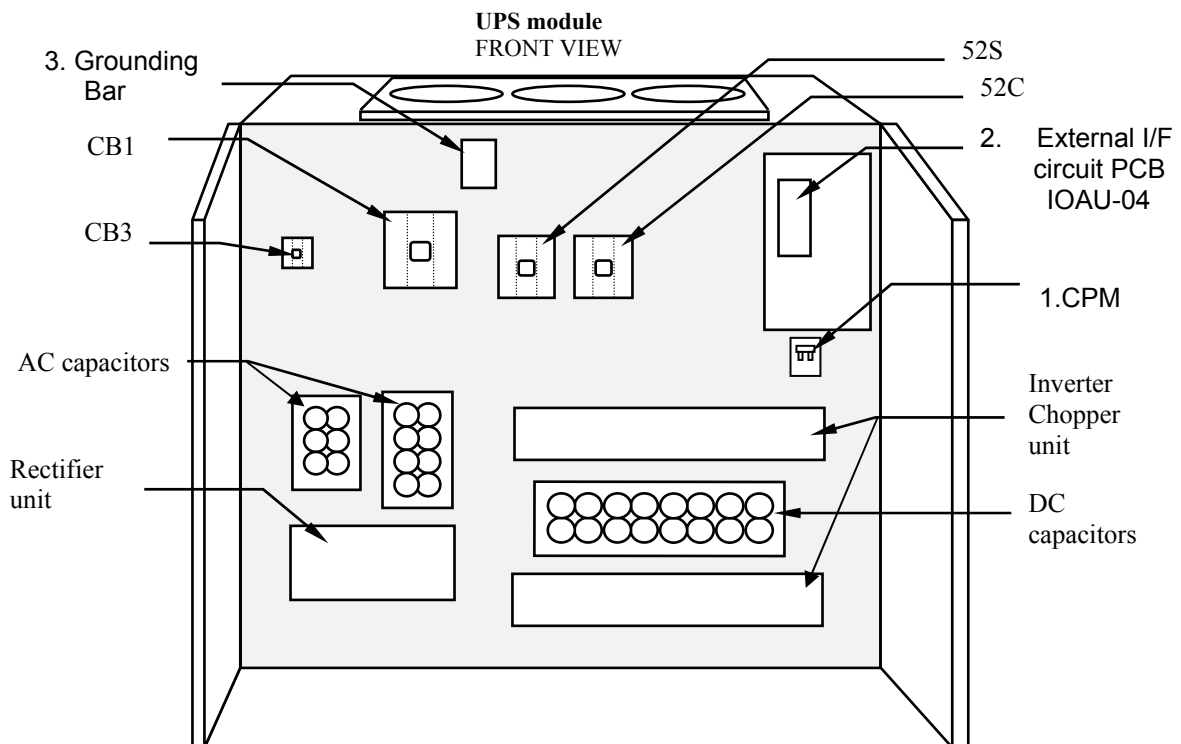

FIGURE 1.4-c UPS Parts Location (500kVA)

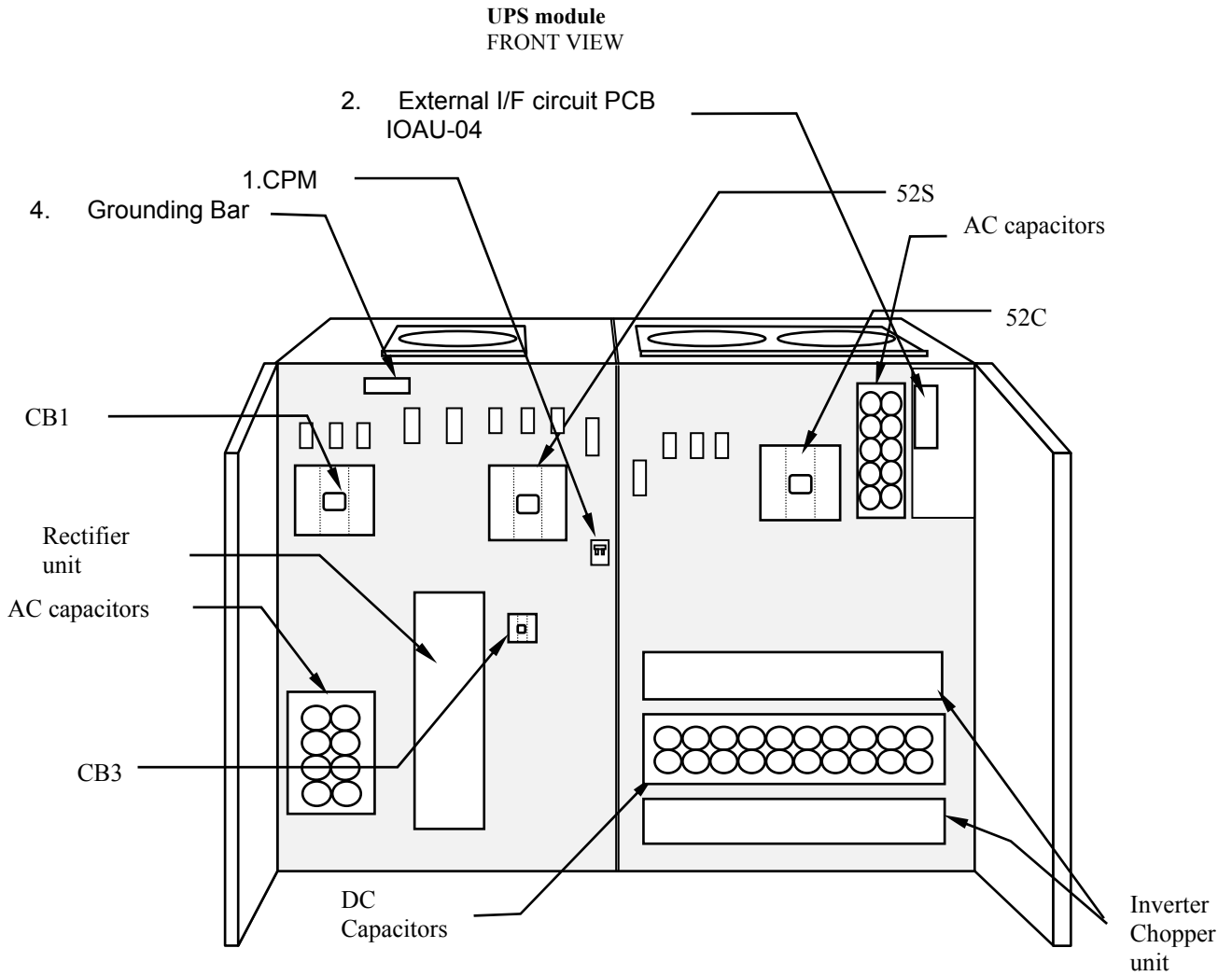

FIGURE 1.4-d UPS Parts Location (750kVA)

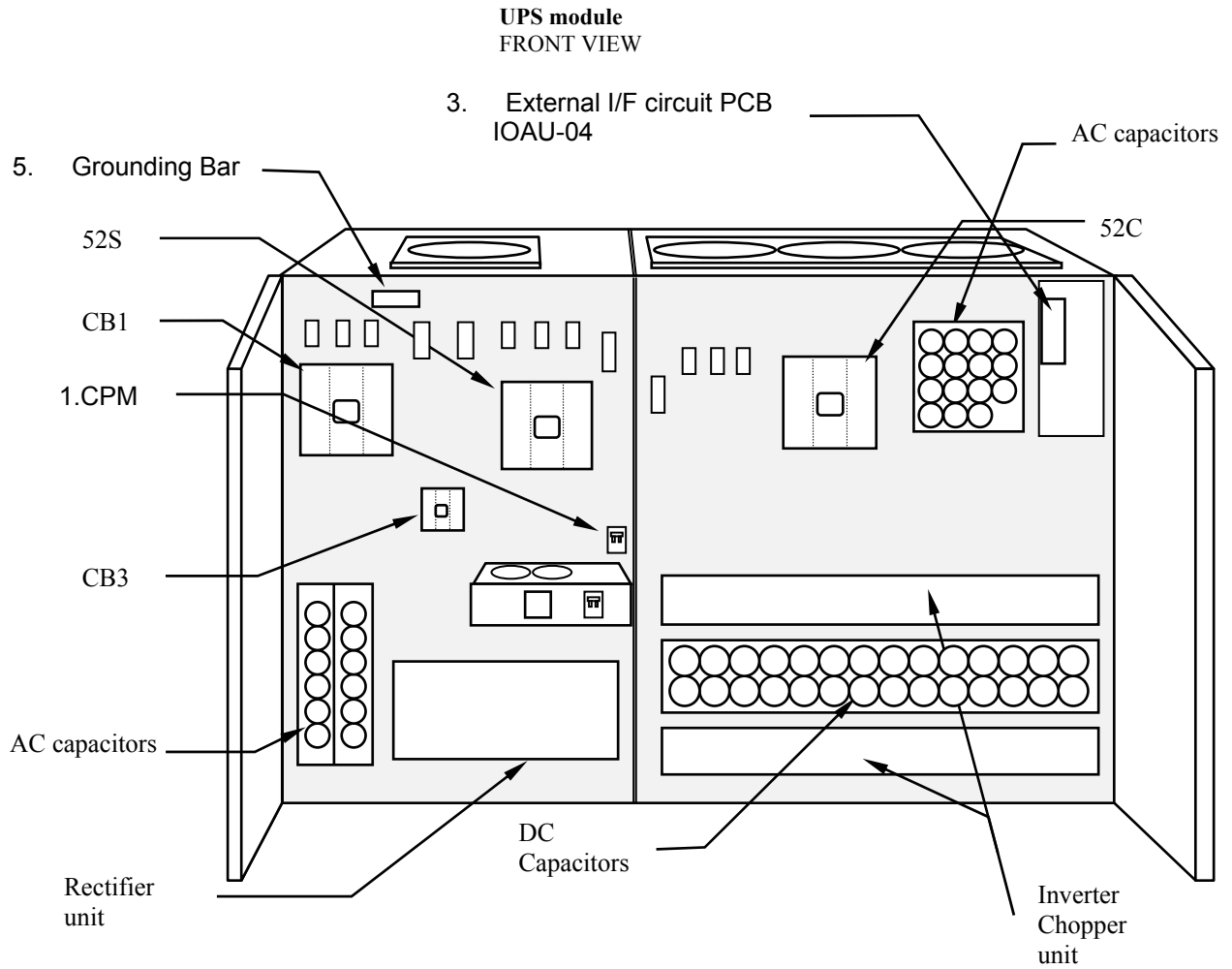

FIGURE 1.5 UPS Parts Location (Continued)

UPS module
REAR OF FRONT DOOR (Right side)

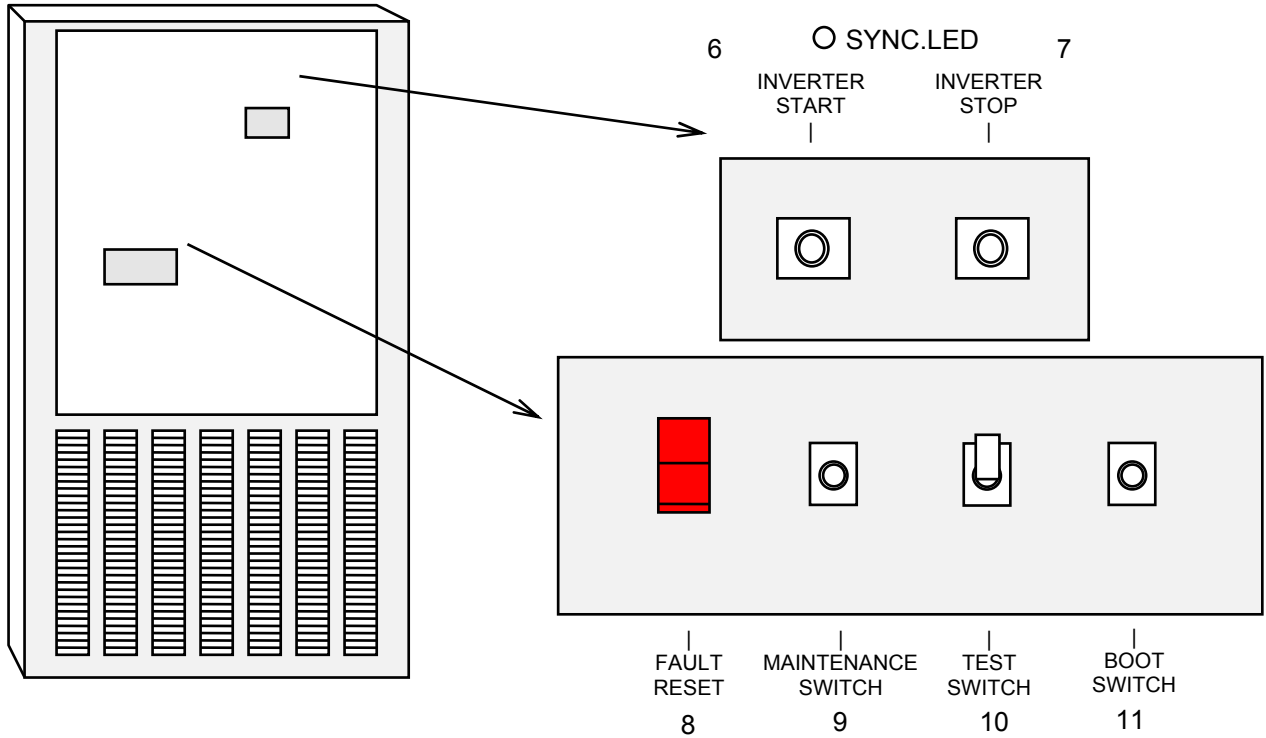
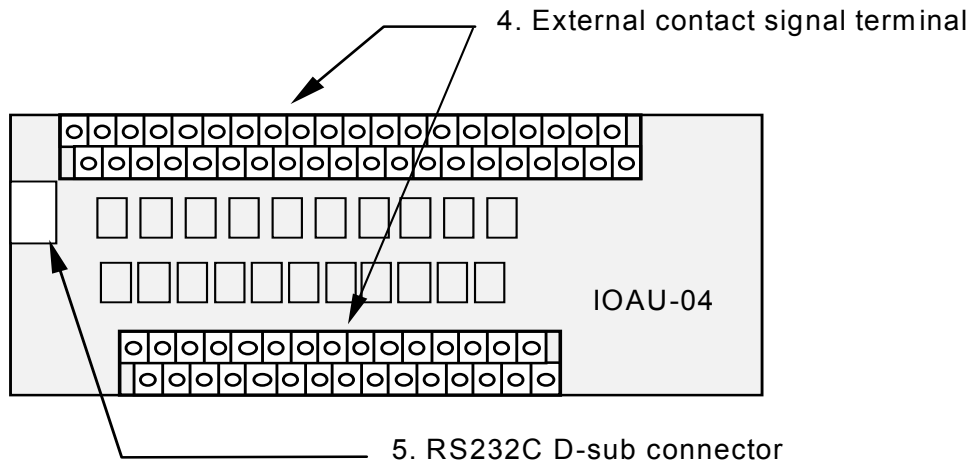

FIGURE 1.6 External I/F circuit PCB IOAU-04



Description of Figures 1.4, 1.5, and 1.6:

1. **CPM** – Circuit protector for control power supply.
2. **Switches on IFGR-G board** : FOR SERVICE PERSONNEL ONLY (FIGURE 1.6):
 - (4) External contact signal terminal
 - (5) RS232C communication connector
3. **Grounding bar (G)**
4. **External contact signal terminal block** - Terminal block to connect contact signal input/output lines to and from the external devices. Refer to Figure 2.15 section 2.4 for details.
5. **RS232C communication connector** - Refer to Figure 2.18 section 2.5 for details.
6. **Inverter start switch** - This switch is used to transfer the UPS from static bypass to inverter during maintenance purposes. Transfers will lock-out if the bypass voltage is more than +12%,-12% of nominal.
** Uninterrupted switching is made at the time of synchronous operation. Switching is impossible at the time of asynchronous operation.*
7. **“INVERTER STOP” switch** - This switch is used to transfer the UPS from inverter to static bypass during maintenance purposes. Do not operate it under normal operation. Transfers will lock-out if the bypass voltage is more than +12%,-12% of nominal.
** Uninterrupted switching is made at the time of synchronous operation. Switching is impossible at the time of asynchronous operation.*
8. **“FAULT RESET” switch (FOR SERVICE PERSONNEL ONLY)** - This switch resets errors resulting from alarm conditions. (Do not operate this switch while inverter and converter are in operation.)
9. **Maintenance (Set) button (FOR SERVICE PERSONNEL ONLY)** - This switch sets the UPS menu parameters.
10. **“Test mode” switch (FOR SERVICE PERSONNEL ONLY)** - This switch changes system operation to the test-mode. (This switch should not be operated by personnel other than an Authorized Service Engineer).
11. **“BOOT” switch (FOR SERVICE PERSONNEL ONLY)** - This switch boots the processor in the main control circuit resulting from alarm conditions. (Do not operate this switch while inverter and converter are in operation).

1.4 Specifications

The UPS name plate displays the rated kVA as well as nominal voltages and currents. The name plate is located on the inside of the UPS front door.

TABLE 1.1 Power Specifications

Rated output Power	Input voltage 3 phase / 3 wire	Bypass input voltage 3 phase / 4 wire	Output voltage 3 phase / 3 or 4 wire
100kVA / 80kW	480V	480V or 600V	480V or 600V
150kVA / 120kW	480V	480V or 600V	480V or 600V
225kVA / 180kW	480V	480V or 600V	480V or 600V
300kVA / 270kW	480V	480V or 600V	480V or 600V
375kVA / 338kW	480V	480V or 600V	480V or 600V
500kVA / 450kW	480V	480V or 600V	480V or 600V
750kVA / 675kW	480V	480V or 600V	480V or 600V

TABLE 1.2 UPS Module Information

UPS [kVA]	CABLE ENTRY	WIDTH [in / mm]	DEPTH [in / mm]	HEIGHT [in / mm]	WEIGHT [lb./ kg]	HEATING [kBTU/h]
100	BOTTOM	43.3 / 1100	29.8 / 758	79.7 / 2025	2100 / 950	22.0
150	BOTTOM	47.2 / 1200	29.8 / 758	79.7 / 2025	2820 / 1275	33.0
225	BOTTOM	55.1 / 1400	29.8 / 758	79.7 / 2025	3310 / 1500	45.0
300	TOP	76.8 / 1950	37.7 / 958	79.7 / 2025	4990 / 2260	68.0
375	TOP	76.8 / 1950	37.7 / 958	79.7 / 2025	5250 / 2380	84.0
500	TOP	114.2 / 2900	37.7 / 958	79.7 / 2025	6930 / 3140	98.0
750	TOP	129.9 / 3300	49.5 / 1258	79.7 / 2025	9655 / 4380	136.1

TABLE 1.3 Detail of Specifications

Rated Output kVA	100	150	225	300	375	500	750
Rated Output kW	80	120	180	270	338	450	675
AC INPUT							
Configuration	3 phase, 3 wire						
Voltage	277/480 V, 346/600 V +15% to -15%						
Frequency	60 Hz +/-5%						
Reflected Current THD	6% max. at 100% load; 9% max. at 50% load						
STATIC BYPASS INPUT							
Configuration	3 phase, 4 wire						
Voltage	277/480 V, 346/600 V +/-10%						
Frequency	60 Hz						
BATTERY							
Type	Lead Acid						
Ride Through	Application Specific						
Nominal Voltage	480 Vdc						
Minimum Voltage	400 Vdc						
Number of Cells	240						
AC OUTPUT							
Configuration	3 phase, 4 wire						
Voltage	277/480 V, 346/600 V						
Voltage Stability	+/-1%						
Frequency	60 Hz						
Frequency Stability	+/-0.05% in free running mode						
Power Factor	0.8 nominal			0.9 nominal			
Power Factor range	0.8 to 1.0 lagging (within output kW rating)						
Voltage THD	2% maximum THD at 100% Linear Load 5% maximum THD at 100% non-linear load						
Transient Response	+/-2% maximum at 100% load step +/-1% maximum at loss/return of AC power +/-5% maximum at load transfer to/from static bypass						
Transient Recovery	Less than 20ms						
Voltage Unbalance	1% maximum at 100% unbalanced load						
Phase Displacement	1deg. maximum at 100% load						
Inverter Overload	125% for 10 minutes; 150% for 1 minute						
System Overload	1000% for 1 cycle (with bypass available)			500% for 1 cycle (with bypass available)			
Bypass Overload	125% for 10 minutes						
Withstand Rating	65kA*						* : with optional fuse
ENVIRONMENTAL							
Cooling	Forced Air						
Operating Temperature	32° F to 104° F (0° C to 40° C). Recommended : 68° F to 86° F (20° C to 30° C)						
Relative Humidity	5% ~ 95% Non Condensing						
Altitude	0 to 9000 feet No Derating						
Location	Indoor (free from corrosive gases and dust)						
Paint Color	Munsell 5Y7/1 (Beige)						

TABLE 1.4 Rating of Contactors and Fuses

	NUMBER	APPLICATION	OUTPUT CAPACITY OF EQUIPMENT													
			100kVA		150kVA		225kVA		300kVA		375kVA		500kVA		750kVA	
			480V	600V	480V	600V	480V	600V	480V	600V	480V	600V	480V	600V	480V	600V
	CB1	AC input contactor	135A		200A		350A		450A		660A		660A		910A	
	CB2	Battery disconnect breaker	400A		600A		800A		1200A		1600A		(MEAU)		(MEAU)	
	CB3	STS contactor	135A											260A		
	52C	Inverter output contactor	135A		200A		350A		450A		450A		660A		910A	
	52S	Bypass contactor	135A		200A		350A		450A		450A		660A		910A	
	88RC	Control circuit contactor	90A													
F U S E S	FCU, FCV, FCW	AC input fuse	200A/660V		250A/660V						315A/660V					
	FIU, FIV,	Inverter output fuse	250A/660V		200A/660V		315A/660V		315A/660V		315A/660V		315A/660V		315A/660V	
	FUA, FUB, FUC	Control power fuse	30A/600V													
	(OPTION) FSU, FSV, FSW	Bypass input fuse	200A/ 660V	-	315A/ 660V	-	250A/ 660V	-	250A/ 660V	-	315A/ 660V	-	315A/ 660V	-	315A/ 660V	-
	FZS1, 2, 3	Bypass input ZNR fuse	16A/500V													
	FBS1, 2, 3	Control power fuse	10A/600V													
	FZR1, 2, 3	AC input ZNR fuse	16A/500V													
	FPU, FPV, FPW	Parallel control circuit fuse	10A/600V													

**Rating would be changed.*

2.0 OPERATOR CONTROLS AND INDICATORS

The 9800A Series operator controls and indicators are located as follows:

- Circuit breakers and contactors: Inside the module
- UPS status indicators: Outside of front door

FIGURE 2.1 Operation/Display Panel (Front panel)

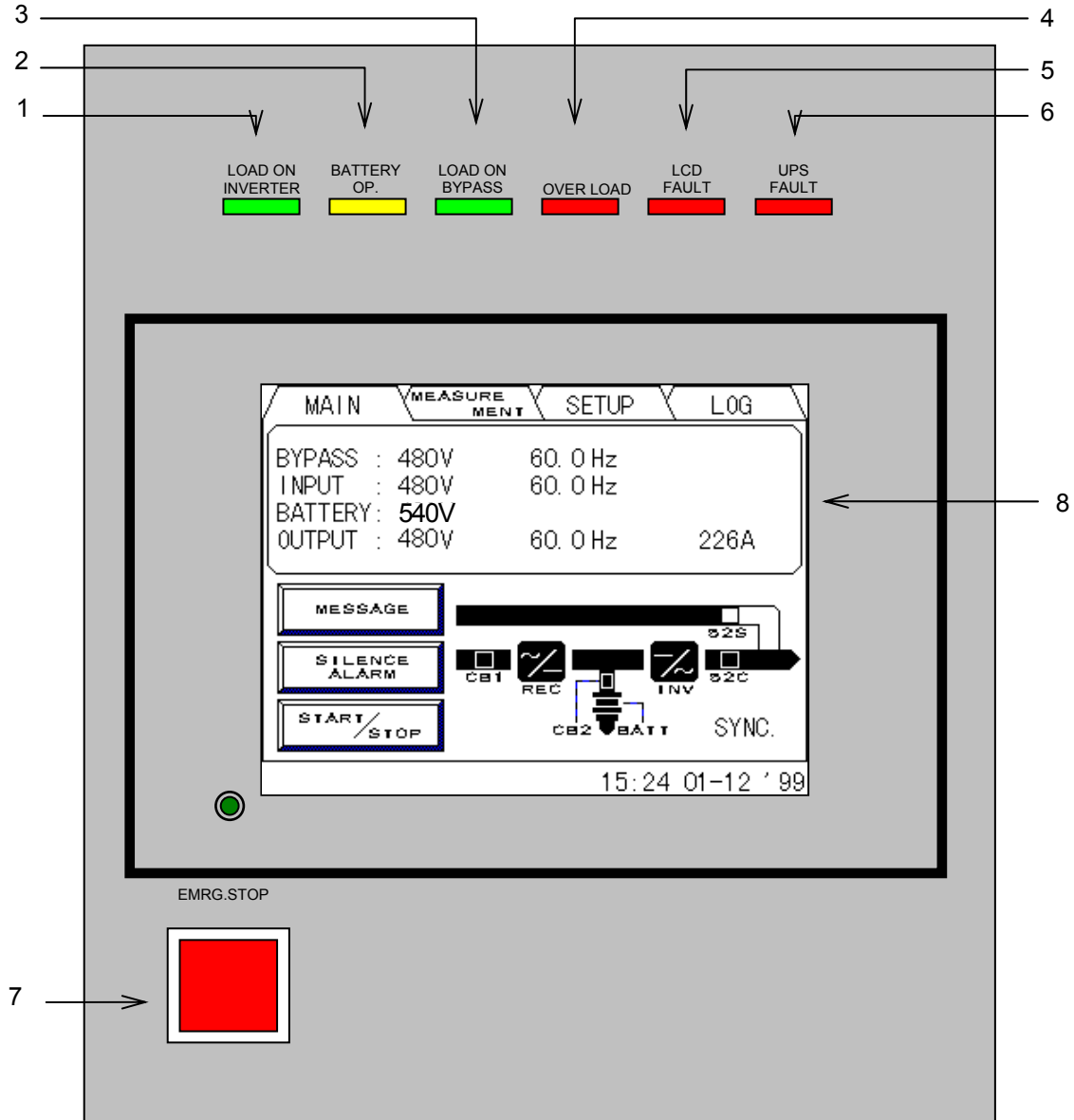

2.1 LED Display

- 1) **Load on inverter [LOAD ON INVERTER](green)**
Illuminates when power is supplied from inverter to the critical load.
(Indicates the state of inverter transfer switch "52C".)
- 2) **Battery operation [BATTERY OP.](yellow)**
Illuminates when power is supplied from batteries following a power failure.
- 3) **Load on bypass [LOAD ON BYPASS](green)**
Illuminates when power is supplied to load devices by static bypass.
(Indicates the state of bypass transfer switch "52S".)
- 4) **Overload [OVERLOAD](red)**
Illuminates in overload condition.
- 5) **LCD fault [LCD FAULT](red)**
Illuminates when an error occurs.
- 6) **UPS fault [UPS FAULT](red) [Annunciator: intermittent or constant tones]**
Illuminates when an error occurs in the system. In this case, the details of the error are indicated on the display panel.

2.2 EPO button (Emergency Power Off button) (7)

When activated, the Emergency Power Off (EPO) function shuts down the UPS module. The critical load will lose power and also shutdown. The EPO function can be performed both locally or remotely.

2.3 Liquid Crystal Display (8)

The Liquid Crystal Display (LCD) panel indicates power flow, measured values, operational guidance, data records and error messages. The LCD panel has a back-light which facilitates viewing in different ambient lighting conditions. The LCD will automatically clear and turn off, if the screen is not activated within 3 minute period. The LCD is turned back on when it is touched again. The ERROR indicator is cleared after 24 hours and can be reproduced by pressing any key on the panel.

2.3.1 Menu

A) MAIN MENU (FIGURE 2.2)

The LCD panel indicates power flow and measured values, while also operating the start/stop function. The LCD panel also allows the user to verify the status and operation of the UPS Module.

FIGURE 2.2 Main screen

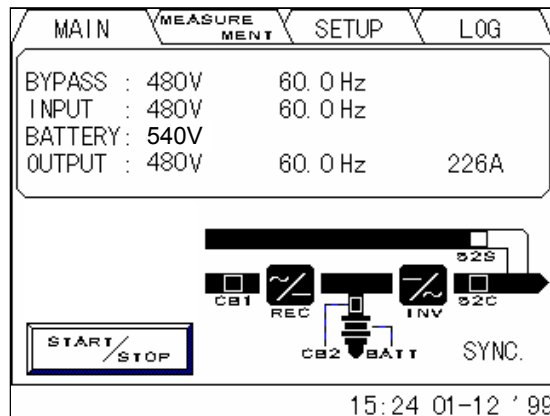

The following will be displayed when the START/STOP key on the LCD panel is pressed:

1) Start/Stop screen (FIGURE 2.3)

The display indicates the start and stop operations for the UPS system. If this operation is PIN protected, the user is required to enter the security PIN before the screen can be accessed. Refer to (FIGURE 2.4).

When in remote mode, the message "REMOTE operating model" will appear on this Screen. The user cannot operate the start and stop functions without changing the setup from remote mode to local mode.

When bypass voltage is abnormal, the message "Bypass voltage abnormal" will appear.

-Start: When the bypass voltage is abnormal, the LCD asks the operator if an interrupted transfer is acceptable (Load may be lost). (FIGURE 2.5)

-Stop: When the bypass voltage is abnormal, the user cannot transfer from inverter to bypass line.

FIGURE 2.3 Start/Stop screen

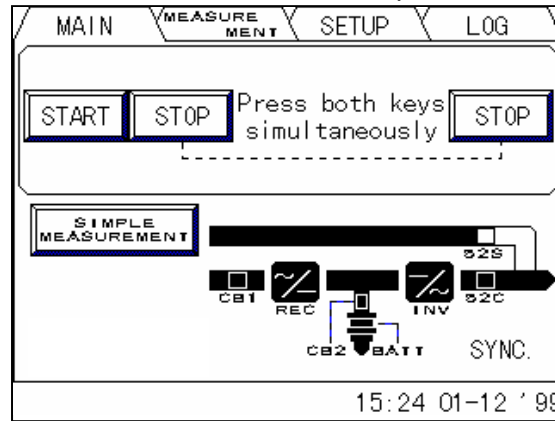

FIGURE 2.4 PIN protection screen

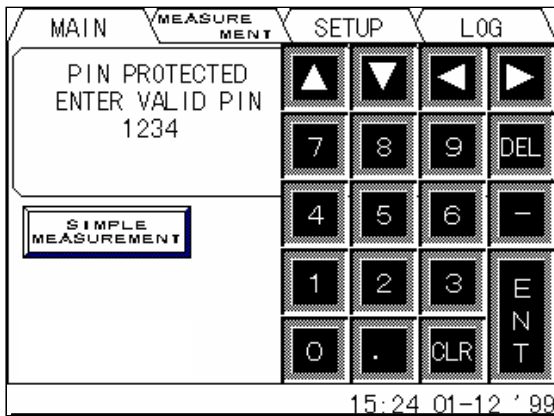
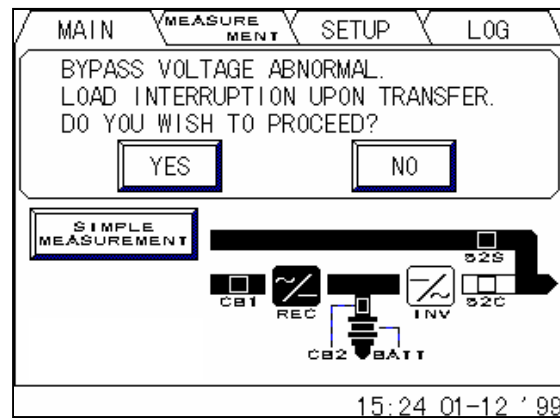

FIGURE 2.5 Bypass voltage abnormal message screen



B) MEASUREMENT MENU (FIGURE 2.6)

This screen shows details of measured values. Bypass voltage, input voltage, output line to line voltage and output frequency are displayed. Output currents are displayed as RMS values.

FIGURE 2.6 Measurement screen

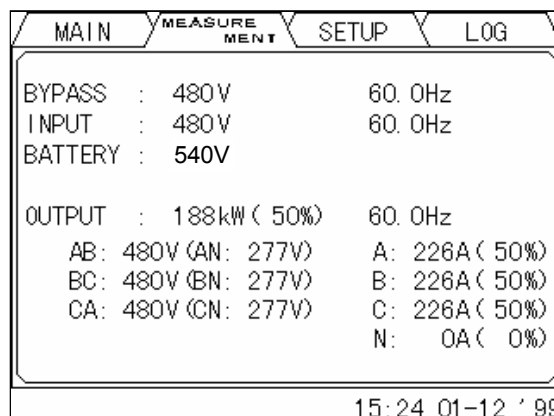

C) SETUP MENU (FIGURE 2.7)

This screen prompts the user to select: (a) whether the start & stop operation will be performed by local or remote operation; (b) date & time adjustment; (c) battery equalizing charge. The battery equalizing charge operation key will appear when battery equalizing charge is set up (Setup is based on battery type).

FIGURE 2.7 Setup screen

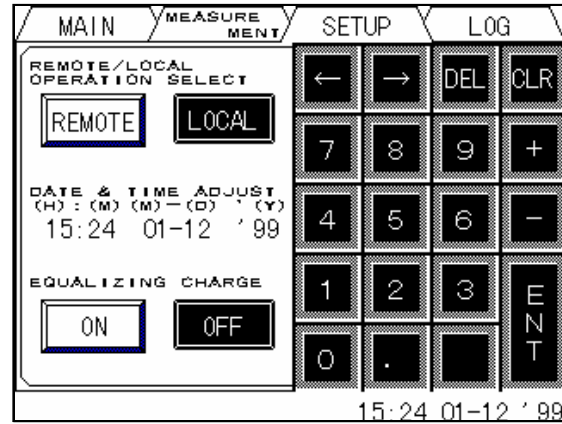

D) LOG MENU (FIGURE 2.8)

This menu shows operation / failure and battery discharge records.

FIGURE 2.8 Log select screen

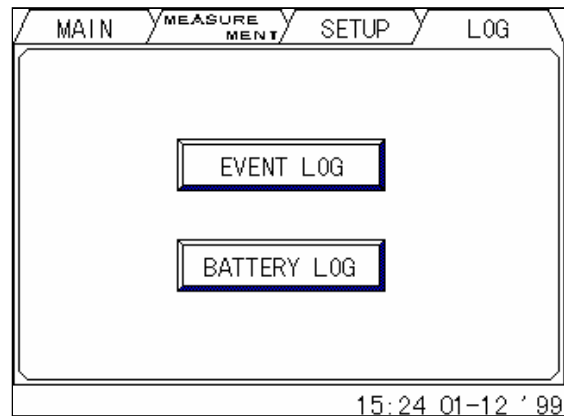

1.) Event log (FIGURE 2.9)

Operation and failure records are indicated. Maximum of 50 events are displayed.

FIGURE 2.9 Event log screen

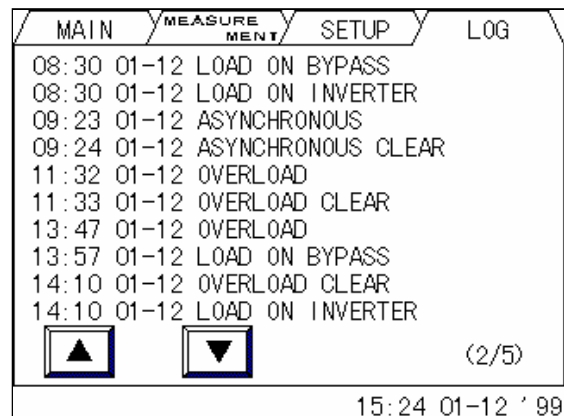

2.) Battery log (FIGURE 2.10)

This screen displays the cumulative battery discharging record.

FIGURE 2.10 Battery log screen

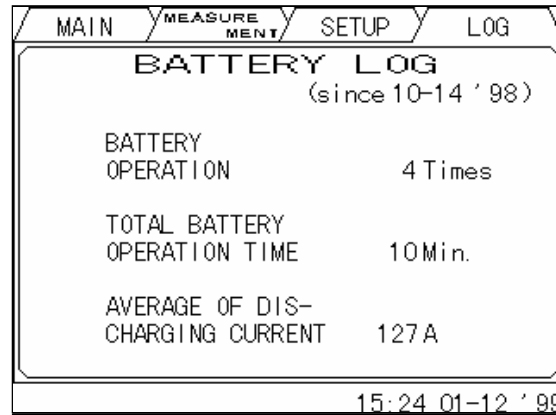

2.3.2 INPUT POWER FAILURE

During an Input Power Failure, the UPS inverter will be powered by the UPS batteries. The following will be displayed on the main and measurement screen (Indication of battery operation and remaining battery life).

FIGURE 2.11 Main screen
(Battery operation)

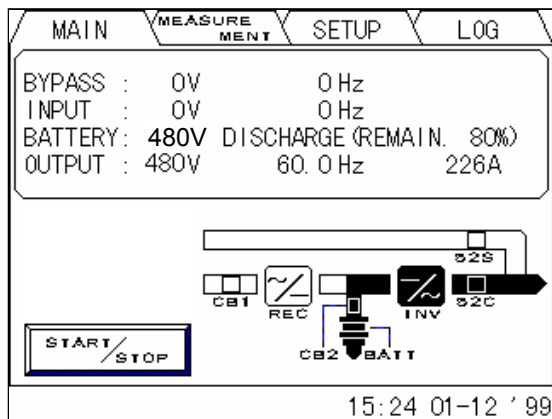
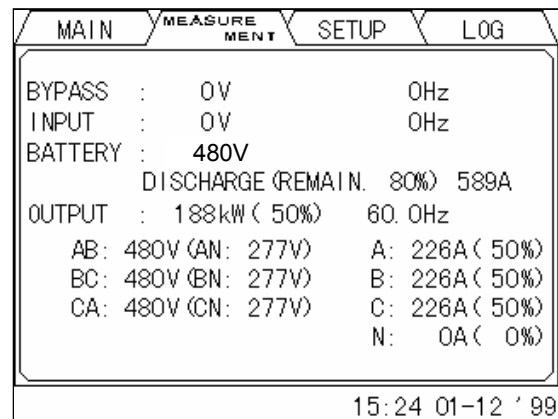

FIGURE 2.12 Measurement screen
(Battery operation)



The LCD will display a battery low voltage message when the battery capacity is near depletion. The End of Battery Discharge announcement is displayed when the battery end voltage is reached. At this time, the inverter will perform an electronic shutdown to prevent battery loss of life typical from extreme deep discharge conditions. When the input power is restored, the inverter will automatically restart to power the load, and the batteries will be simultaneously recharged. The End of Battery announcement is shown at the bottom of the screen.

2.3.3 FAULT INDICATION (FIGURE 2.13)

“MESSAGE” and “SILENCE ALARM” buttons will appear on the main menu when UPS failure condition has occurred.

FIGURE 2.13 Main screen (Fault indication)

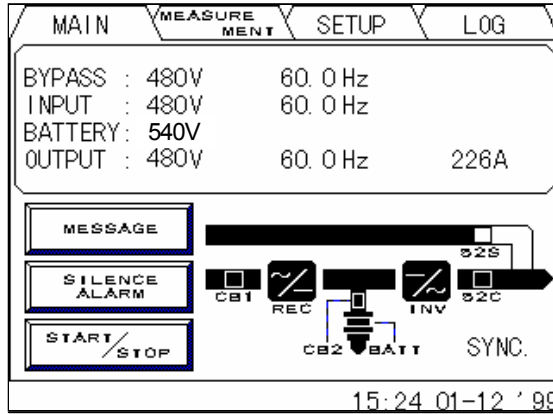

The following will be displayed when the message key on the LCD panel is pressed.

1) Message (FIGURE 2.14)

The display shows a fault code, the description of the fault and a guidance of what action is to be taken by the user. A maximum of 10 faults is displayed at one time. If an input power failure occurs during a fault condition, the fault indication and input power failure announcement are alternatively displayed at 5 second intervals.

FIGURE 2.14 Message screen

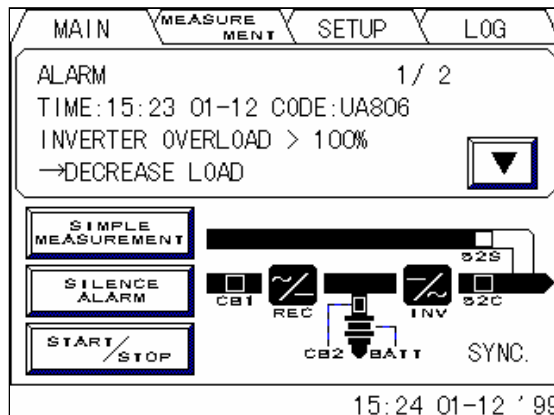

2) Silence alarm

This key will appear when a failure occurs. The audible alarm (announcing the failure) can be silenced by pressing this key.

2.4 External Signal Terminal Block

The UPS is equipped with a series of input/output terminals for external annunciation of alarms and for remote access of certain UPS functions. The layout of terminals is shown in Figure 2.15. with a functional description of the input/output port presented. OUT1 to OUT6 are user programmable, but are factory default set being also shown in Figure 2.15.

FIGURE 2.15-1 External Signal Terminal Block (NEC Class2)

TN1

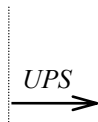
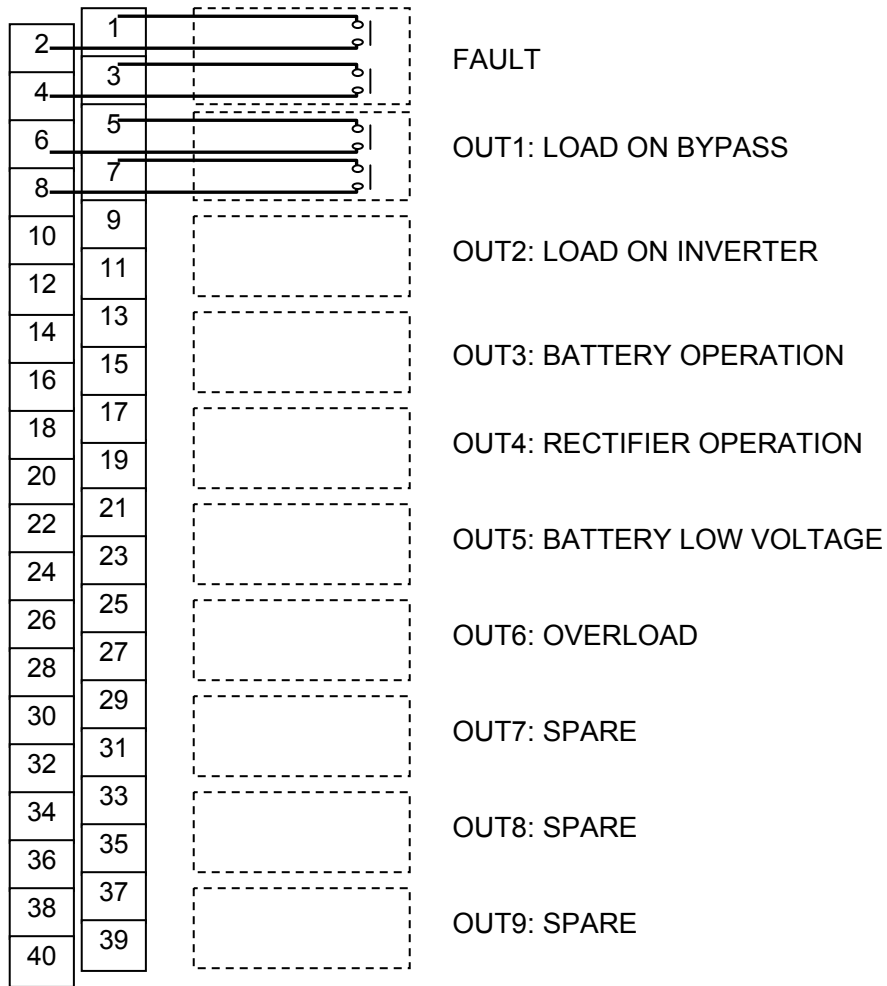
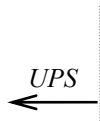
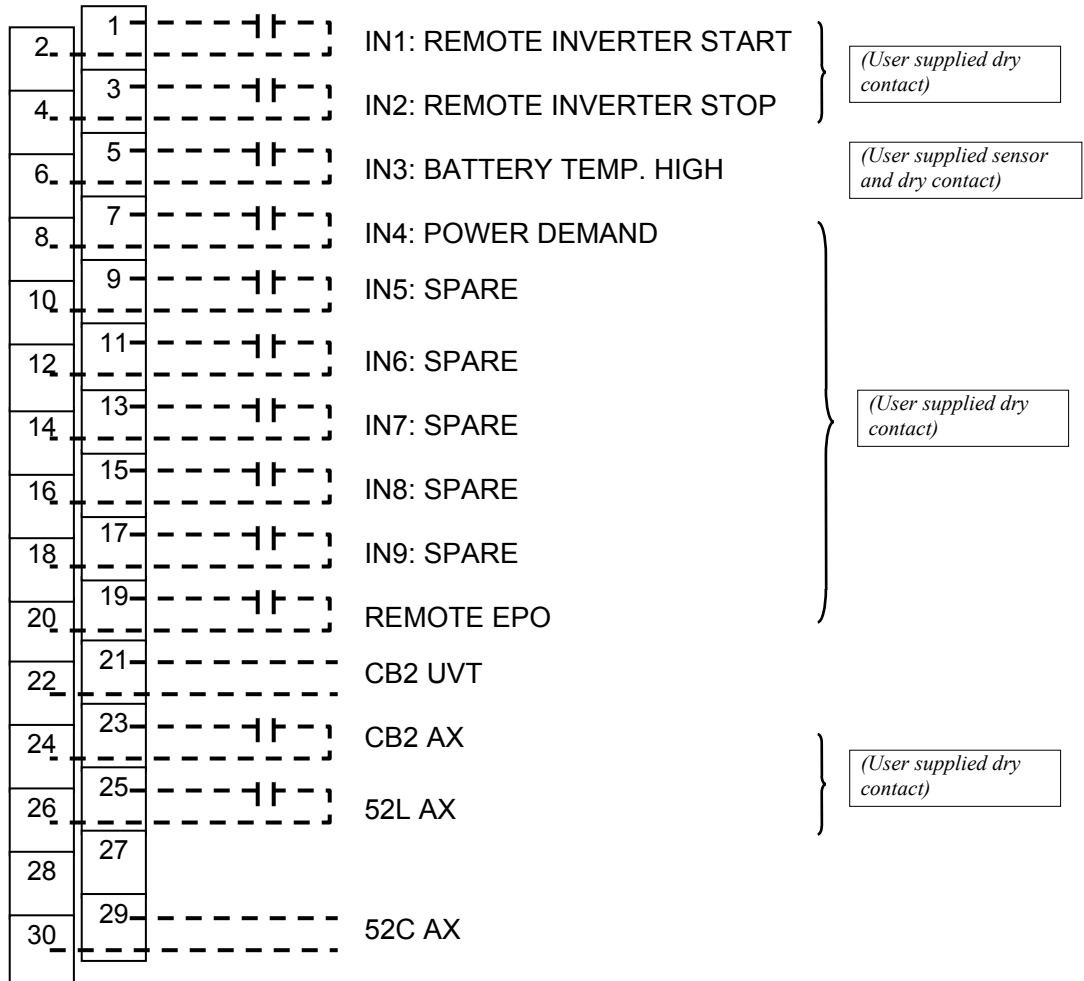

FIGURE 2.15-2 External Signal Terminal Block (NEC Class2)

TN2



A) Output Contacts (for external alarm annunciation)

Output contacts consist of form “A” dry type contacts. Rated capacity of all output contacts is NEC Class2 (30Vdc/1Adc). All dry contacts should be operated at their rated values or lower. Figure 2.16 illustrates a typical installation. The external relay can also be a lamp, LED, computer, etc.

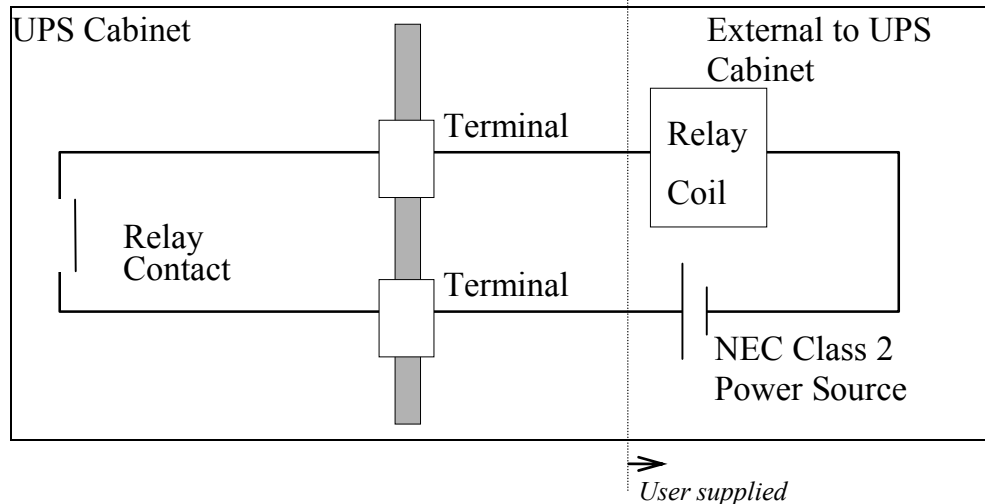
FIGURE 2.16 Control Wiring for External Contacts

Details of output alarm contacts : TN1
Terminals 1 to 2, 3 to 4 "UPS failure" contact

Activated when a major fault has occurred with the system.

Terminals 5 to 6, 7 to 8 "Load on Bypass" contact (OUT1)

Activated when the power is supplied from the static bypass input.

Terminals 9 to 10, 11 to 12 "Load on Inverter" contact (OUT2)

Activated when the power is supplied by the inverter.

Terminals 13 to 14, 15 to 16 "Battery Operation" contact (OUT3)

Activated when the battery is operating following an AC power failure.

Terminals 17 to 18, 19 to 20 "Rectifier Operation" contact (OUT4)

Activated when the rectifier is operating.

Terminals 21 to 22, 23 to 24 "Battery Low Voltage" contact (OUT5)

Activated when the battery voltage drops below discharge end voltage level during inverter operation (i.e. During AC fail condition).

Terminals 25 to 26, 27 to 28 "Overload" contact (OUT6)

Activated when an overload has occurred to the system.

Terminals 29 through 40 "Spare" contact (OUT7 through OUT9)



NOTE: *The UPS is equipped with a selectable output contact feature. The above alarms are the default settings. Contact **MITSUBISHI ELECTRIC AUTOMATION, INC.** for setup information.*

B) Input Contacts (for remote access of UPS)

External contacts are provided by the user of the UPS system. Terminal voltage at the UPS is 24Vdc. Provide external dry contact accordingly.



NOTE: *Do not apply voltages to remote access input terminals. Damage to UPS may result.*

Refer to Figure 2.17 for a typical wiring configuration. Although this figure applies to the remote start/stop terminals, the same wiring arrangement is used for emergency stop; battery liquid low; and battery temperature high.

FIGURE 2.17 Remote "Start" Contact Connections

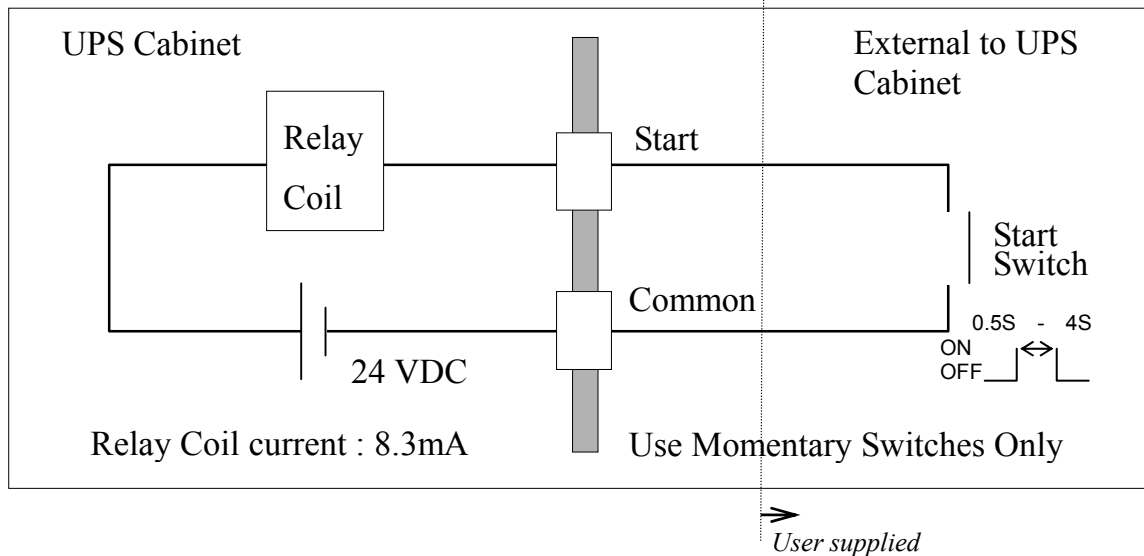

Details of input contacts for remote access : TN2

Terminals 1 to 2 Remote "Inverter Start" input terminal (IN1)

Used to start inverter from a remote location. UPS must be programmed for remote operation. Refer to Operations Menu for procedure.

Terminals 3 to 4 Remote "Inverter Stop" input terminal (IN2)

Used to stop inverter from a remote location. UPS must be programmed for remote operation. Refer to Operations Menu for procedure.

Terminals 5 to 6 "Battery Temp. High" contact input (IN3)

Input fed by a thermocouple that monitors battery temperature. The converter float voltage level is reduced for battery over-temperature conditions. External thermocouple is user supplied

Terminals 7 to 8 **"Power Demand Command" contact input (IN4)**

This contact is used to control the input power. Power demand is turned ON when the contact is closed, and power demand is turned OFF when the contact is open.

Terminals 9 to 18 **"Spare" contact input (IN5 through IN9)**

Terminals 19 to 20 **"Remote EPO" contact input**

Used to perform a remote UPS Emergency Power Off (EPO).

The load will be dropped.



NOTE: *The UPS is equipped with a selectable output contact item. The above items are the default settings. Contact **MITSUBISHI ELECTRIC AUTOMATION, INC.** for setup information.*



NOTE : *In all cases, a switch having a protective cover is recommended in order to reduce the possibility of accidental operation.*

2.5 External communication connector

This is an RS232C port for "DiamondLink"* monitoring software. The layout of connector is shown in Figure 2.18.

FIGURE 2.18 External communication connector (NEC Class2)

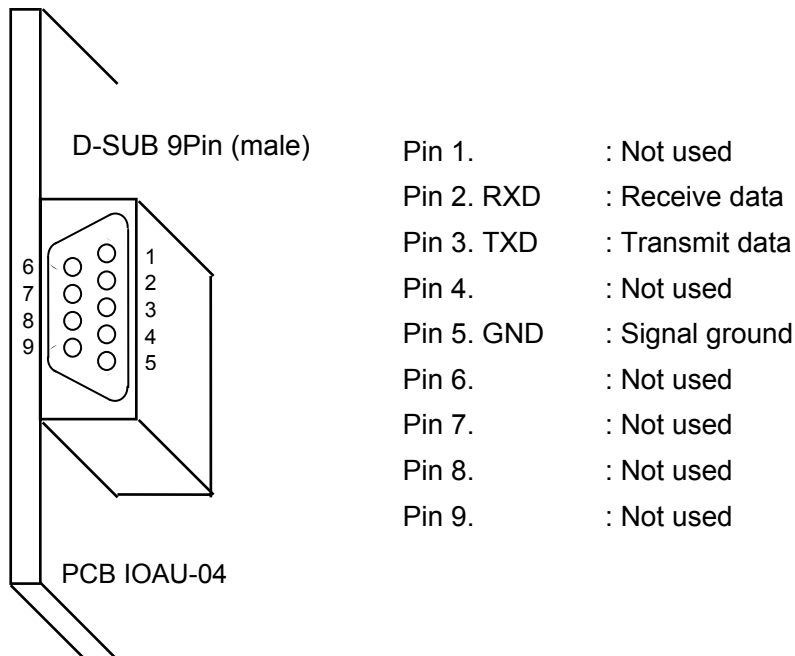

* Consult MITSUBISHI ELECTRIC AUTOMATION, INC. for details on "DiamondLink" monitoring software and its capabilities.

3.0 INSTALLATION AND OPERATION

3.1 Transportation and Installation

TABLE 3.1 How to transport and install the system

Transportation	Installation
Transport unit with forklift. Carry with overhead crane using eyebolts provided.	Using the pre drilled holes (4 - 24) in the UPS channel base, anchor the unit using appropriate hardware. (Not provided)



Note : *Do not transport in a horizontal position. Cabinets must be maintained upright within +/- 15° of the vertical during handling.*

3.2 Installation Procedure

A) Note the load tolerance of the floor

Refer to Table 3.2 for list of UPS weights.

TABLE 3.2 List of UPS weights

UPS Capacity (kVA)	100	150	225	300	375	500	750
Weight (lb.)	2100	2820	3310	4990	5250	6930	9655

B) Minimum clearance required for ventilation

Right side 25 mm (not required when sidecars are used)

Left side 25 mm (not required when sidecars are used)

Back side 0.0 mm

Top side 600 mm (for air flow)

C) Space requirement for routine maintenance

Allow for the following space at the time of installation.

Front 1000 mm 100kVA, 150kVA, 225kVA

1075 mm 300kVA, 375kVA, 500kVA, 750kVA

Sides 0.0 mm

Rear 0.0 mm

D) External Battery Supply

Please refer to the following when installing and maintaining batteries:



1. The customer shall refer to the battery manufacturer's installation manual for battery installation and maintenance instructions.
2. The maximum permitted fault current from the remote battery supply, and the DC voltage rating of the battery supply over-current protective device are shown in Table 3.3.

TABLE 3.3 Maximum Permitted Fault Current

UPS CAPACITY (kVA)	DC VOLTAGE RATING (V)	MAXIMUM PERMITTED FAULT CURRENT (A)
100	480	25000
150	480	25000
225	480	25000
300	480	25000
375	480	25000
500	480	25000
750	480	25000

3.3 Procedure for Cable Connections *

- i. Confirm the capacity of the UPS being installed. Identify the input/output power terminal blocks as shown in the appropriate Figures 3.1 through 3.2-a~g, Figure 3.3. and Figure 3.4a~c. (Note * Figure 3.4a~c shows power and control wire for parallel system.)
- ii. Connect the internal control wire and power wire.
 - (1) Control wire Inter-connect
 1. CB2 Auxiliary to terminal 1, 2.
 2. CB2-UVT to terminal 3, 4.
 3. Parallel configuration Wiring (Refer to Figure 3.4a~c)
 - CLC CB 52L1-AX, 52L2-AX 52Ln-AX to UPSn TB1 (1,2 terminals)
 - Parallel Control CN92, CN93, In, Out cables between UPS modules
 - (2) Power wire Inter-connect
 - a.) From user's distribution panel
 1. X1 (A-phase) to A bus bar in UPS rectifier section.
 2. X2 (B-phase) to B bus bar in UPS rectifier section.
 3. X3 (C-phase) to C bus bar in UPS rectifier section.

- b.) DC Input to UPS
 - 1. Positive cable to BP bus bar in UPS rectifier section.
 - 2. Negative cable to BN bus bar in UPS rectifier section.
- c.) From UPS AC Output Terminals to Critical Load Cabinet (CLC) UPS AC Output Terminals (Refer to Figure 3.4a~c)

- iii. Connect the grounding conductor from the input service entrance to the UPS ground bar.



- iv. Two (2) sources feeding the UPS:

- (1) Connect the rectifier input power cables from the input service entrance to the rectifier input power terminals, identified as A, B, C in Figures 3.2-a~g. Input cables must be sized for an ampere rating larger than the maximum input drawn by the rectifier. (Refer to equipment nameplate for current ratings.) Confirm that an external bypass input circuit breaker (MCCB) is installed (refer to WARNING 2, page 1-2). Connect the bypass input power cables from the input service entrance to the bypass input power terminals, identified as A40, B40, C40 and N40 in Figures 3.2-a~g. Bypass input cables must be sized for an ampere rating larger than the maximum output current capacity of the UPS. Refer to Table 3.4 for recommended cable sizes.
- (2) Connect the external signal terminal block as desired. Refer to section 2.4 and Figure 2.15 for functional description. 2mm², or less, shielded conductor is recommended.

- v. One (1) source feeding the UPS:

- (1) Confirm that an external input circuit breaker sized to protect both the rectifier input and the bypass line is installed. (Refer to equipment nameplate for current ratings.) Connect the bypass input power cables from the input service entrance to the bypass input power terminals, identified as A40, B40, C40 and N40 in Figures 3.2-a~g. Input cables must be sized for an ampere rating larger than the maximum current capacity of the UPS. Refer to Table 3.4 for recommended cable sizes.
- (2) Using adequately sized conductors and referring to the appropriate figure identified in Figures 3.2-a~g, connect jumper bypass terminals A40, B40, C40 to rectifier input power terminals A, B, C as identified in Figures 3.2-a~g.

- (3) Connect the external signal terminal block as desired. Refer to section 2.4 and Figure 2.15 for functional description. 2mm², or less, shielded conductor is recommended.

NOTES: 1. *Confirm that all UPS internal contactors (breakers) "CB1", "CB2", and "CB3" are open before energizing UPS.*



2. *UPS power terminals are supplied with stud type fittings. It is recommended that compression lugs be used to fasten all input/output power cables.*

TABLE 3.4 Recommended Cable Sizes

kVA Capacity	Input Voltage	Output Voltage	Input Side * 1, 2		Output Side * 1, 2		Bypass Side * 1, 2		DC Input Side * 1, 2	
			Cable Size	Torque in. lbs	Cable Size	Torque in. lbs	Cable Size	Torque in. lbs	Cable Size	Torque in. lbs
100kVA	480V	480V	1 AWG or larger	200 - 269 in. lbs	1 AWG or larger	200 - 269 in. lbs	1 AWG or larger	200 - 269 in. lbs	3/0 AWG or larger	200 - 269 in. lbs
	600V	600V	2 AWG or larger	200 - 269 in. lbs	2 AWG or larger	200 - 269 in. lbs	2 AWG or larger	200 - 269 in. lbs	3/0 AWG or larger	200 - 269 in. lbs
150kVA	480V	480V	3/0 AWG or larger	347 - 469 in. lbs	3/0 AWG or larger	347 - 469 in. lbs	3/0 AWG or larger	347 - 469 in. lbs	350 MCM or larger	347 - 469 in. lbs
	600V	600V	2/0 AWG or larger	347 - 469 in. lbs	2/0 AWG or larger	347 - 469 in. lbs	2/0 AWG or larger	347 - 469 in. lbs	350 MCM or larger	347 - 469 in. lbs
225kVA	480V	480V	300 MCM or larger	347 - 469 in. lbs	350 MCM or larger	347 - 469 in. lbs	350 MCM or larger	347 - 469 in. lbs	2x4/0 AWG or larger	347 - 469 in. lbs
	600V	600V	250 MCM or larger	347 - 469 in. lbs	250 MCM or larger	347 - 469 in. lbs	250 MCM or larger	347 - 469 in. lbs	2x4/0 AWG or larger	347 - 469 in. lbs
300kVA	480V	480V	2x4/0 AWG or larger	347 - 469 in. lbs	2x3/0 AWG or larger	347 - 469 in. lbs	2x3/0 AWG or larger	347 - 469 in. lbs	2x400 MCM or larger	347 - 469 in. lbs
	600V	600V	2x3/0 AWG or larger	347 - 469 in. lbs	400 MCM or larger	347 - 469 in. lbs	400 MCM or larger	347 - 469 in. lbs	2x400 MCM or larger	347 - 469 in. lbs
375kVA	480V	480V	3x300 MCM or larger	347 - 469 in. lbs	2x250 MCM or larger	347 - 469 in. lbs	2x250 MCM or larger	347 - 469 in. lbs	3x350 MCM or larger	347 - 469 in. lbs
	600V	600V	2x4/0 AWG or larger	347 - 469 in. lbs	2x3/0 AWG or larger	347 - 469 in. lbs	2x3/0 AWG or larger	347 - 469 in. lbs	3x350 MCM or larger	347 - 469 in. lbs
500kVA	480V	480V	3x250 MCM or larger	347 - 469 in. lbs	2x400 MCM or larger	347 - 469 in. lbs	2x400 MCM or larger	347 - 469 in. lbs	3x500 MCM or larger	347 - 469 in. lbs
	600V	600V	2x350 MCM or larger	347 - 469 in. lbs	2x300 MCM or larger	347 - 469 in. lbs	2x300 MCM or larger	347 - 469 in. lbs	3x500 MCM or larger	347 - 469 in. lbs
750kVA	480V	480V	3x500 MCM or larger	347 - 469 in. lbs	3x500 MCM or larger	347 - 469 in. lbs	3x500 MCM or larger	347 - 469 in. lbs	5x500 MCM or larger	347 - 469 in. lbs
	600V	600V	3x350 MCM or larger	347 - 469 in. lbs	3x350 MCM or larger	347 - 469 in. lbs	3x350 MCM or larger	347 - 469 in. lbs	5x500 MCM or larger	347 - 469 in. lbs

*1 - The cables must be selected to be equal to or larger than the sizes listed in the table.

*2 - Voltage drop across power cables not to exceed 2% of nominal source voltage.

*3 - Allowable ampere-capacities based on 90° C insulation at ambient temperature of 30° C.

Not more than 3 conductors in a raceway without de-rating.

Note: Copper conductors assumed.

TABLE 3.5 Crimp Type Compression Lug

WIRE SIZE (CODE)	WIRE STRAND CLASS	RECOMMENDATION		CRIMP TOOL REQUIRED BURNDY TYPE Y35 OR Y46	
		VENDOR	CAT. NO.	COLOR KEY	DIE INDEX
1	B	BURNDY	YA1C	GREEN	11 / 375
	I	ILSCO	CRA-1L	GREEN	11 / 375
		BURNDY	YA25-LB	---	1019
1/0	B	BURNDY	YA25	PINK	12 / 348
	I	ILSCO	CRA-1/OL	PINK	12 / 348
		BURNDY	YA25-LB	---	1020
2/0	B	BURNDY	YA26	BLACK	13
	I	ILSCO	CRA-2/OL	BLACK	13
		BURNDY	YA27-LB	---	1021
3/0	B	BURNDY	YA27	ORANGE	14 / 101
	I	ILSCO	CRB-3/OL	ORANGE	14 / 101
		BURNDY	YA28-LB	---	1022
4/0	B	BURNDY	YA28	PURPLE	15
	I	ILSCO	CRB-4/OL	PURPLE	15
		BURNDY	YA29-LB	---	1023
250 MCM	B	BURNDY	YA29	YELLOW	16
	I	ILSCO	CRA-250L	YELLOW	16
		BURNDY	YA30-LB	---	1024
300 MCM	B	BURNDY	YA30	WHITE	17 / 298
	I	ILSCO	CRA-300L	WHITE	17 / 298
		BURNDY	YA32-LB	---	1026
350 MCM	B	BURNDY	YA31	RED	18 / 324
	I	ILSCO	CRA-350L	RED	18 / 324
		BURNDY	YA34-LB	---	1027
400 MCM	B	BURNDY	YA32	BLUE	19 / 470
	I	ILSCO	CRA-400L	BLUE	19 / 470
		BURNDY	YA36-LB	---	1027
500 MCM	B	BURNDY	YA34	BROWN	20 / 299
	I	ILSCO	CRA-500L	BROWN	20 / 299
		BURNDY	YA38-LB	---	1029

NOTE: *When using crimp type lugs, the lugs should be crimped to the specifications given in the manufacturer's instructions for both crimp tool and lug.*

FIGURE 3.1 UPS Terminal Designation

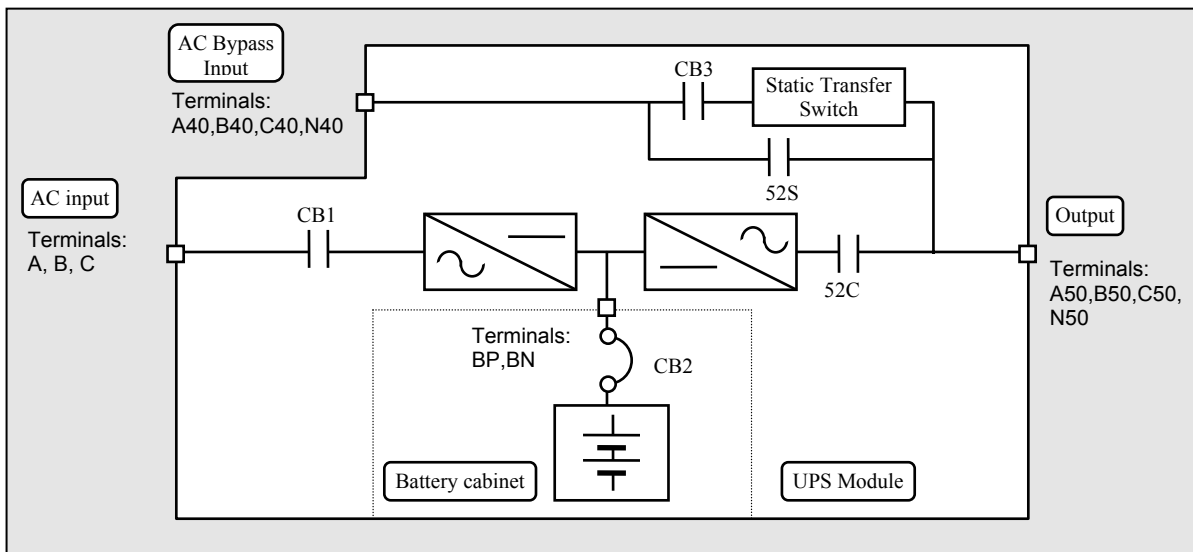

FIGURE 3.2-a-1 Diagram of input/output bus bars and terminal blocks (100kVA, 150kVA, 225kVA UPS, Input voltage 480Vac)

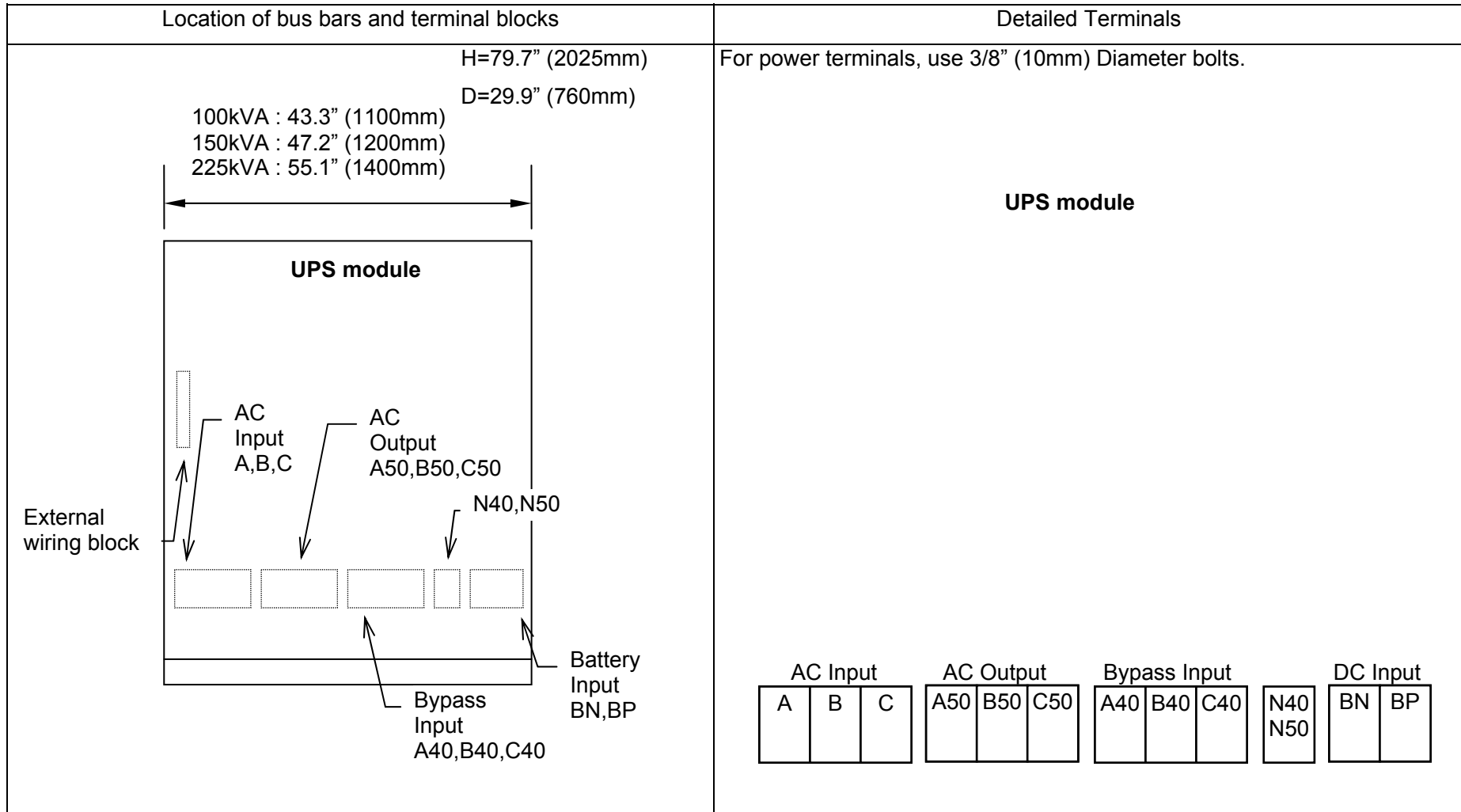

FIGURE 3.2-a-2 Diagram of Power Wire & Control Wire Inter-Connect (100kVA, 150kVA, 225kVA UPS, Input voltage 480Vac)

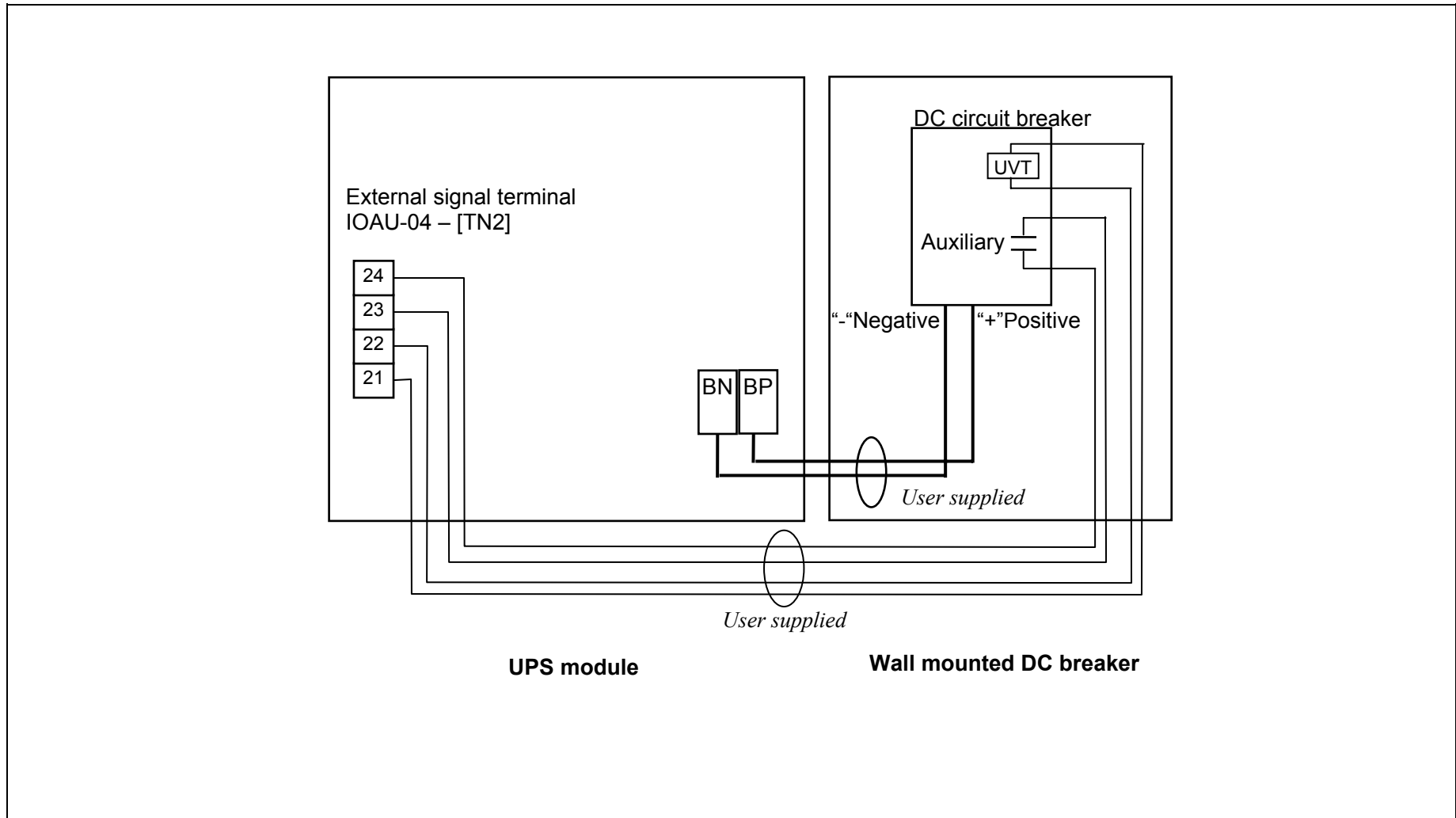

FIGURE 3.2-b-1 Diagram of input/output bus bars and terminal blocks (100kVA, 150kVA, 225kVA UPS, Input voltage 600Vac)

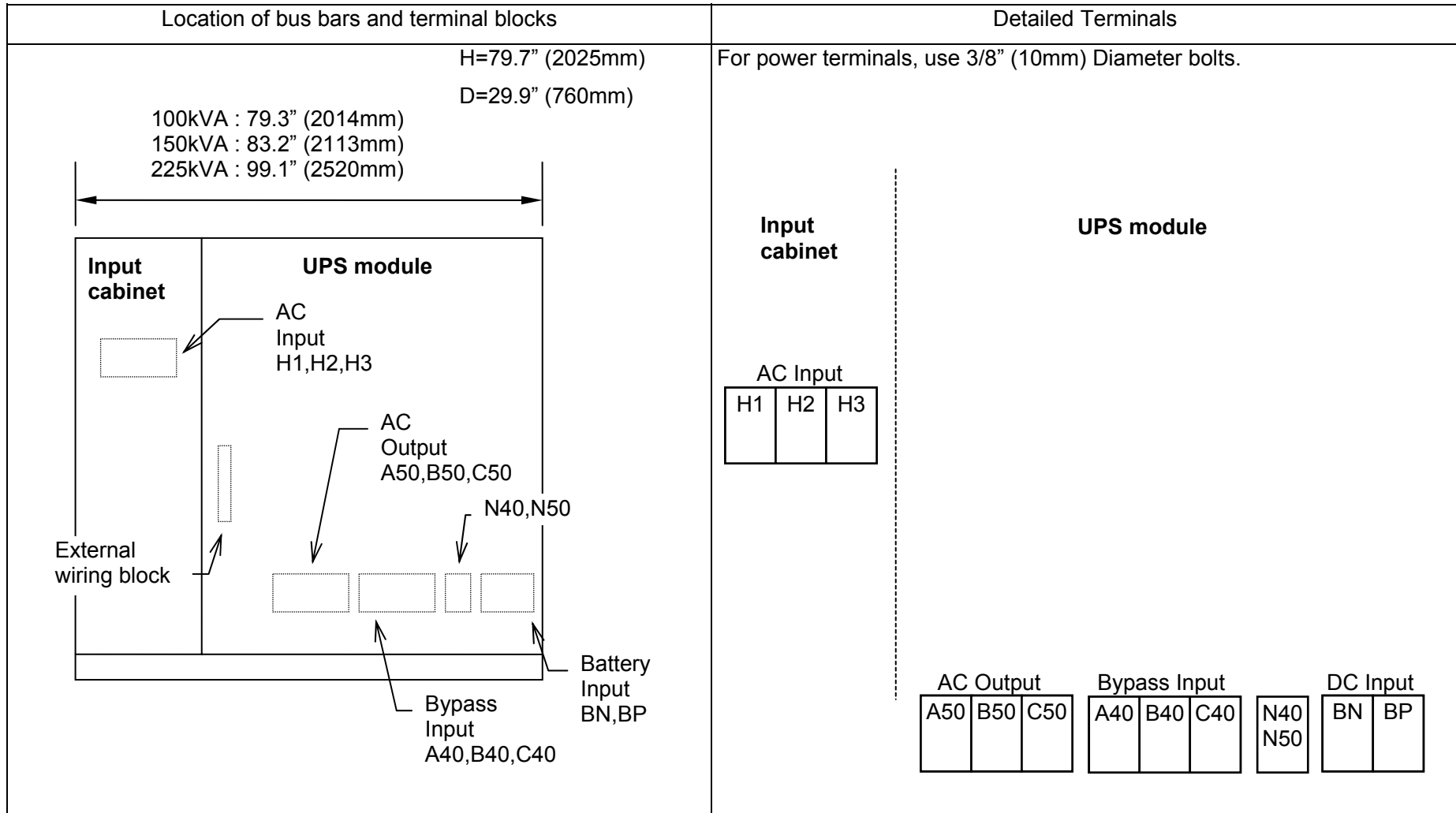

FIGURE 3.2-b-2 Diagram of Power Wire & Control Wire Inter-Connect (100kVA, 150kVA, 225kVA UPS, Input voltage 600Vac)

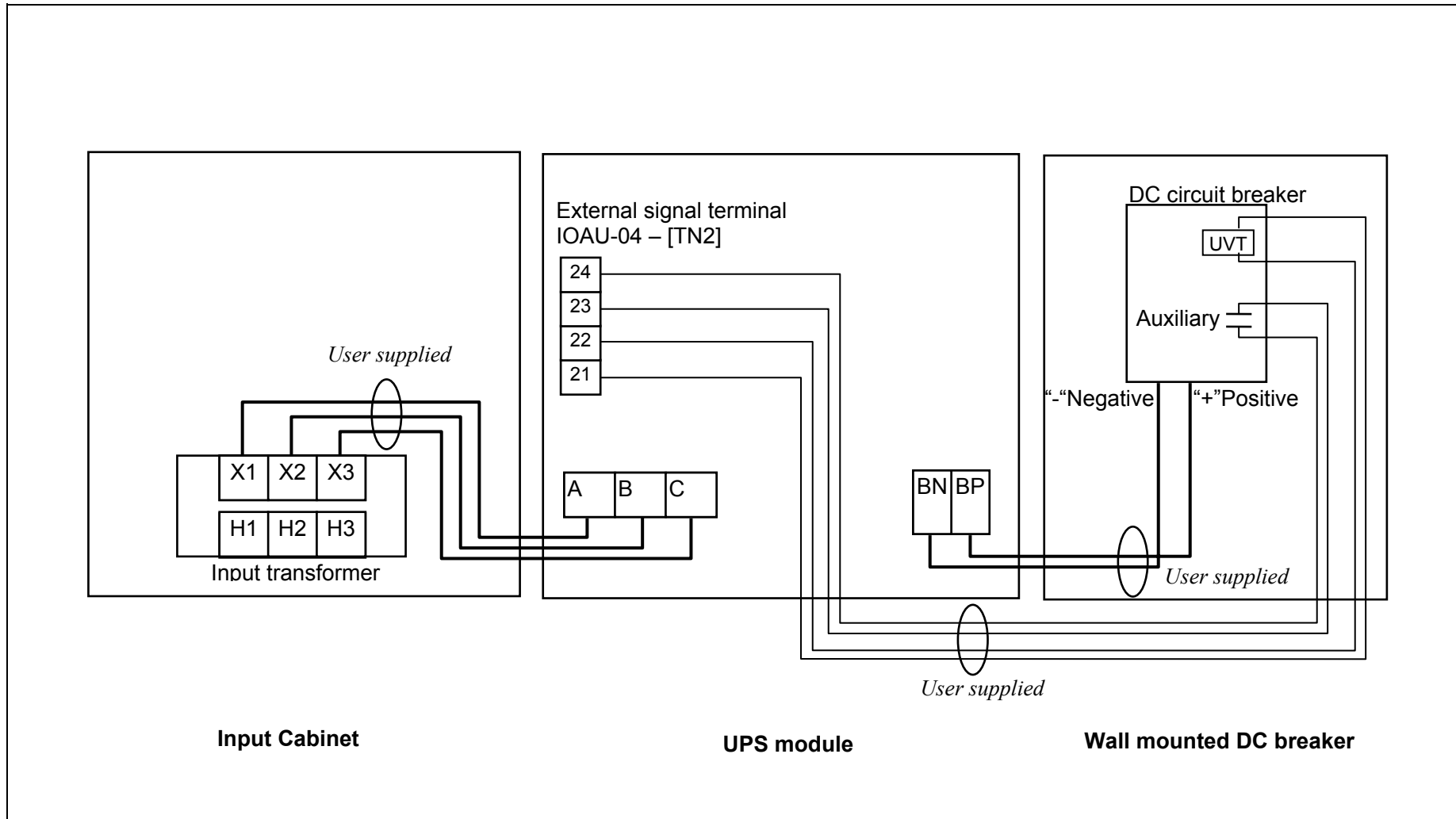

FIGURE 3.2-c-1 Diagram of input/output bus bars and terminal blocks (300kVA, 375kVA UPS, Input voltage 480Vac)

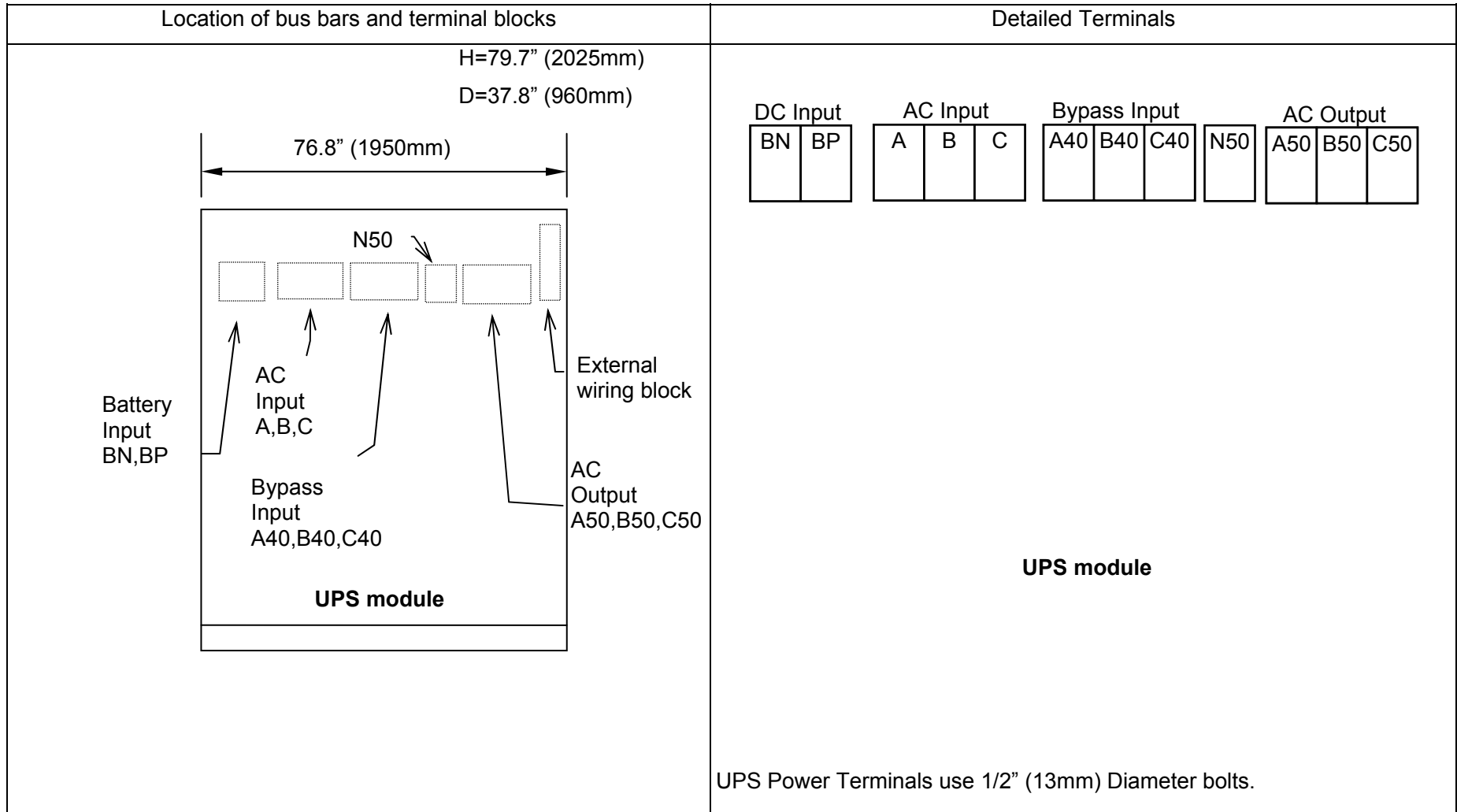

FIGURE 3.2-c-2 Diagram of Power Wire & Control Wire Inter-Connect (300kVA, 375kVA UPS, Input voltage 480Vac)

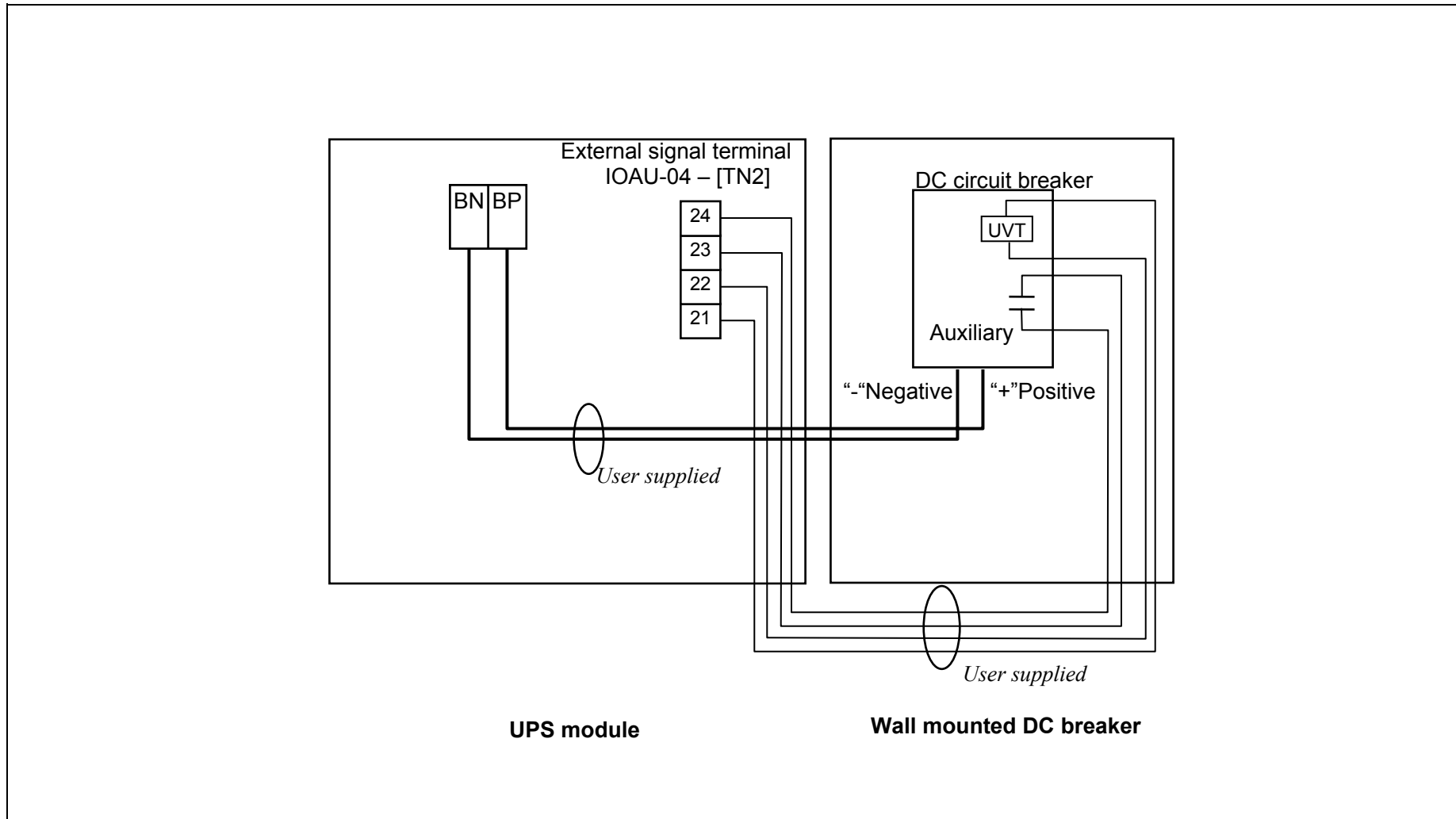

FIGURE 3.2-d-1 Diagram of input/output bus bars and terminal blocks (300kVA, 375kVA UPS, Input voltage 600Vac)

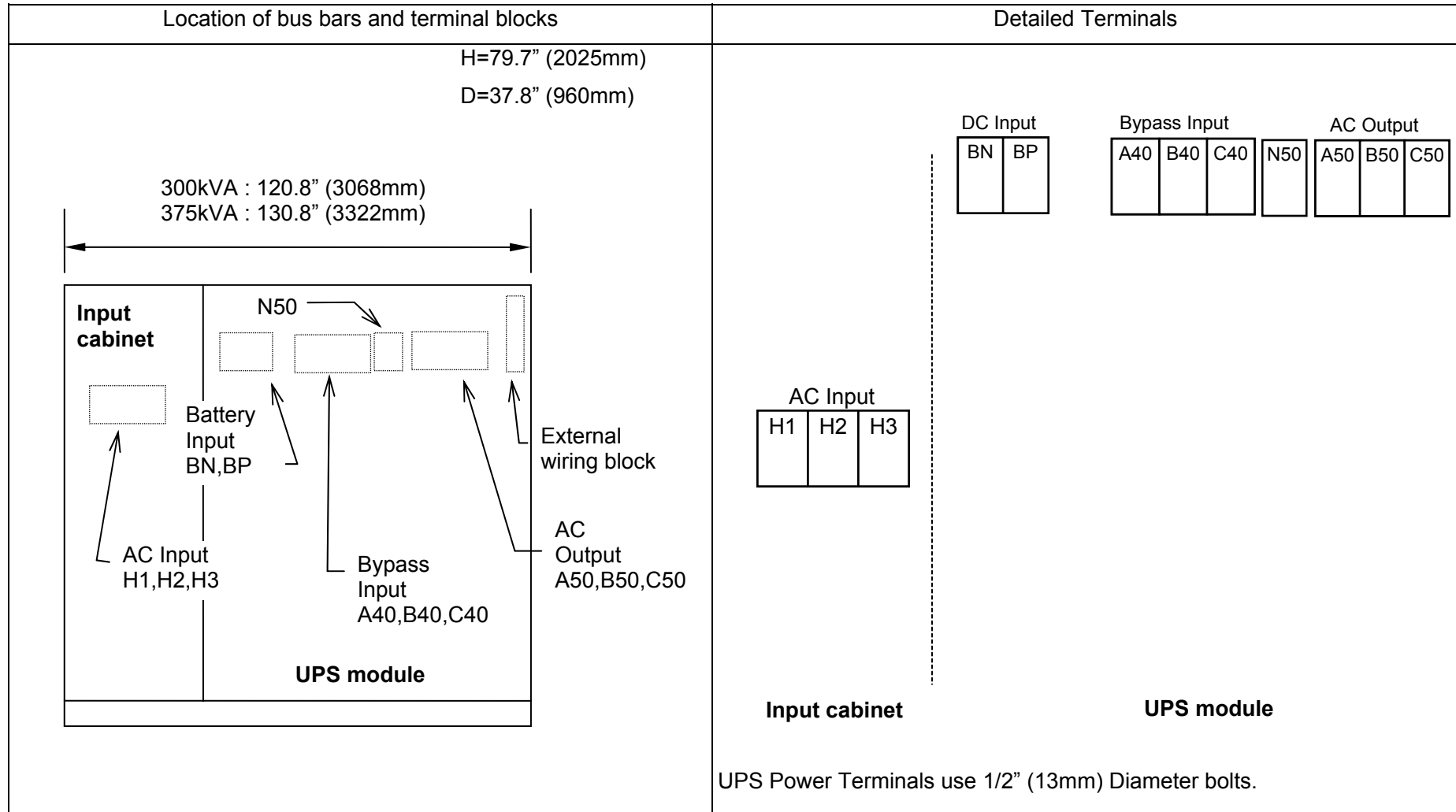

FIGURE 3.2-d-2 Diagram of Power Wire & Control Wire Inter-Connect (300kVA, 375kVA UPS, Input voltage 600Vac)

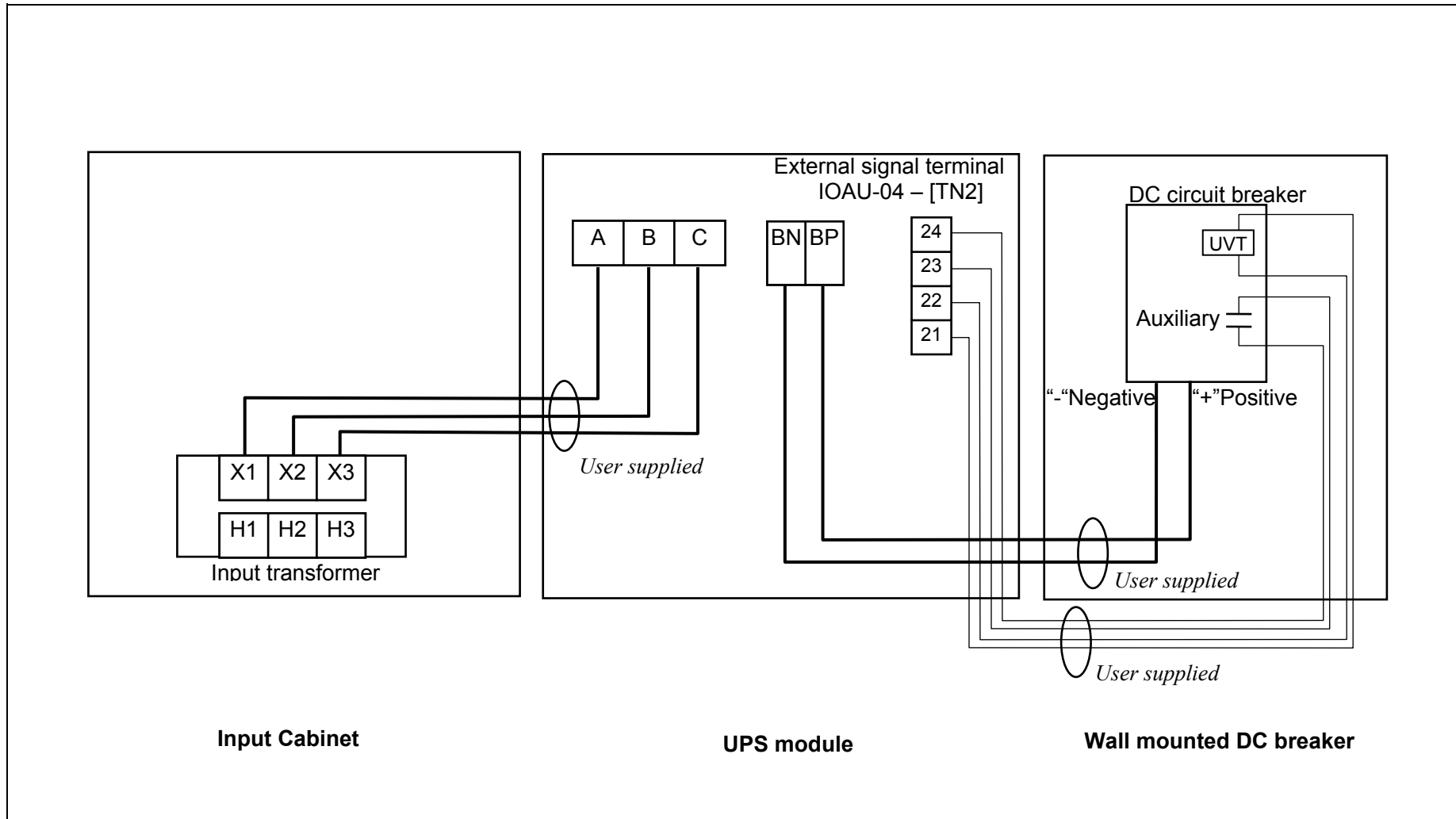

FIGURE 3.2-e-1 Diagram of input/output bus bars and terminal blocks (500kVA, 750kVA UPS, Input voltage 480Vac)

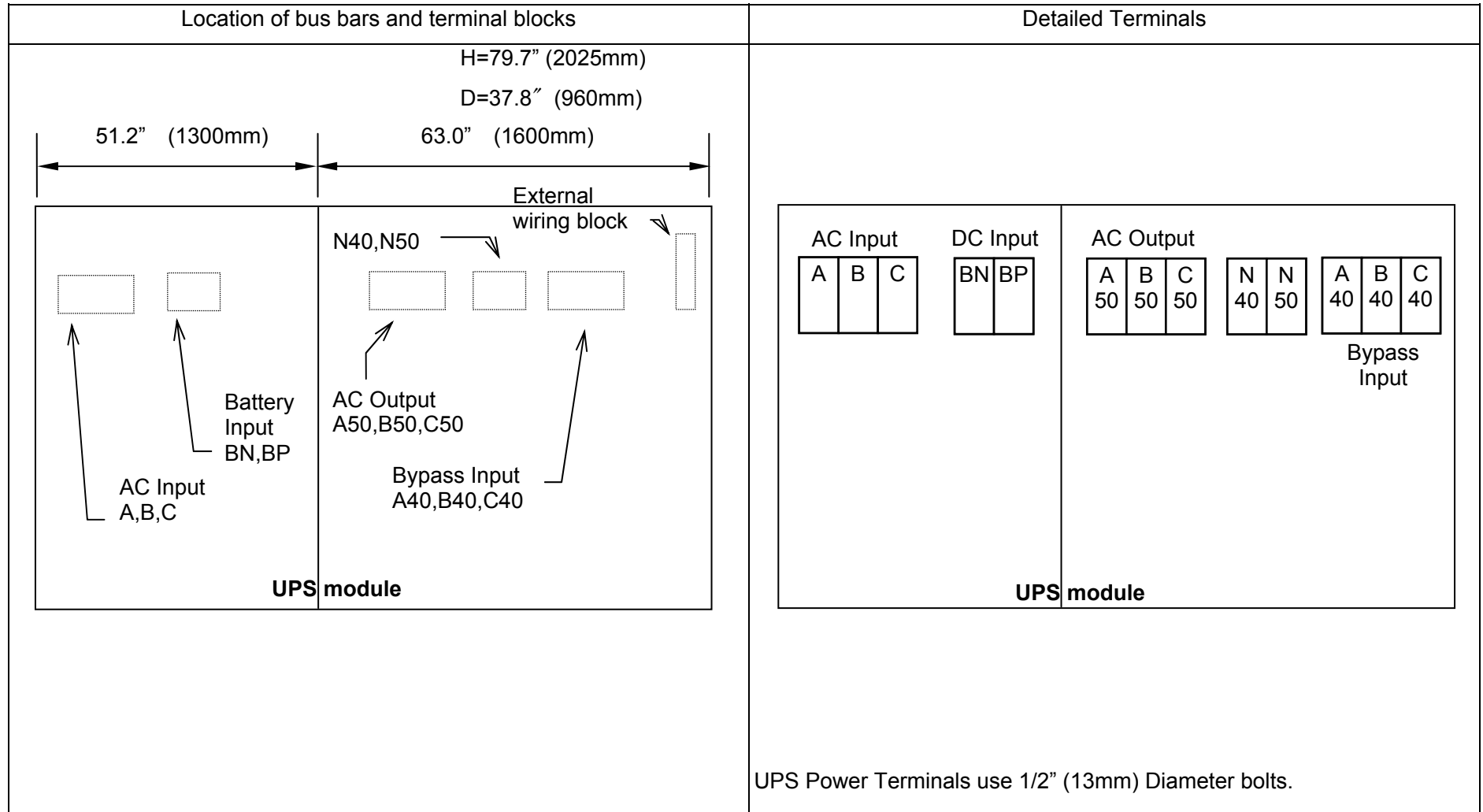

FIGURE 3.2-e-2 Diagram of Power Wire & Control Wire Inter-Connect (500kVA, 750kVA UPS, Input voltage 480Vac)

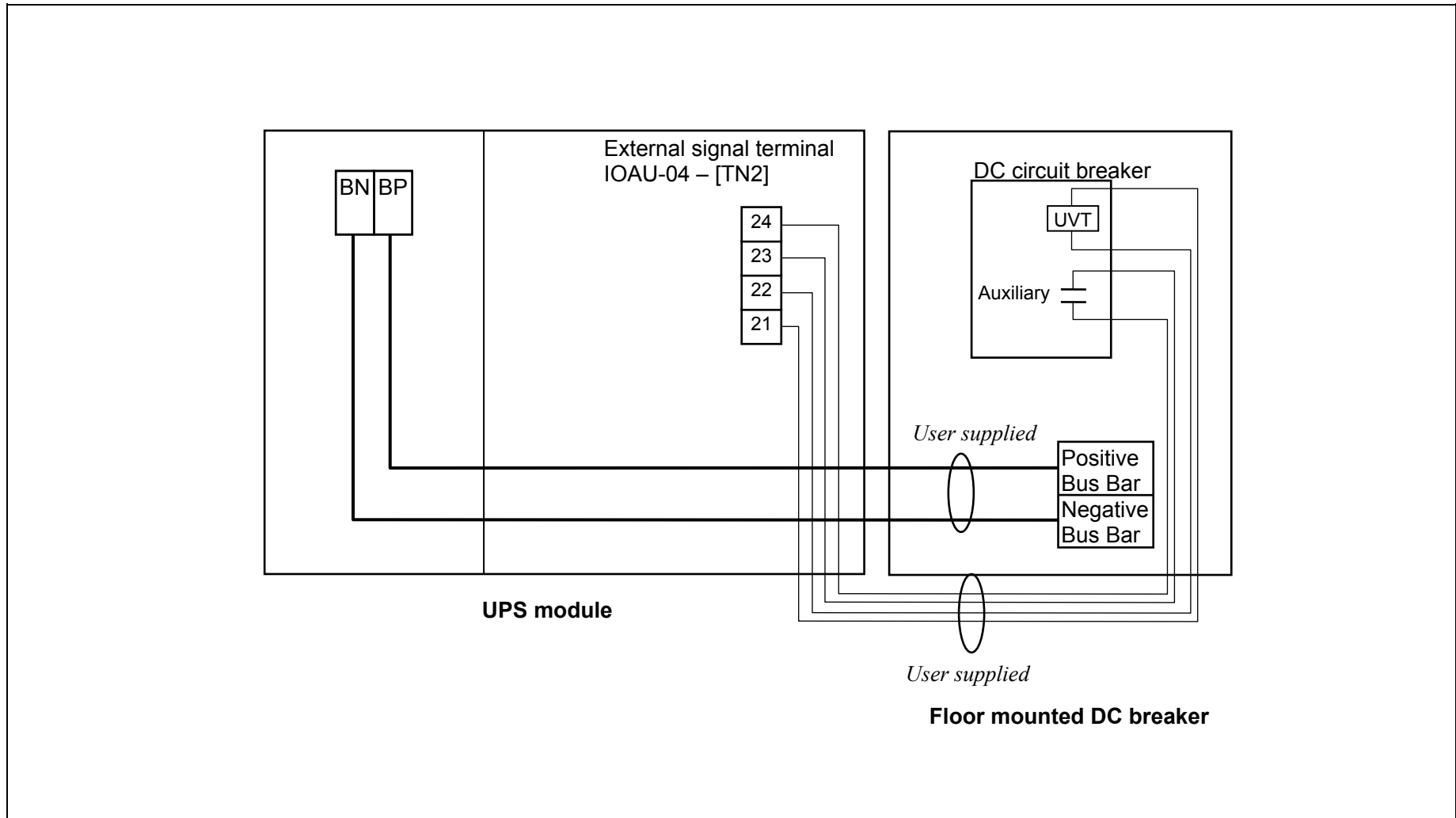

FIGURE 3.2-f-1 Diagram of input/output bus bars and terminal blocks (500kVA, 750kVA UPS, Input voltage 600Vac)

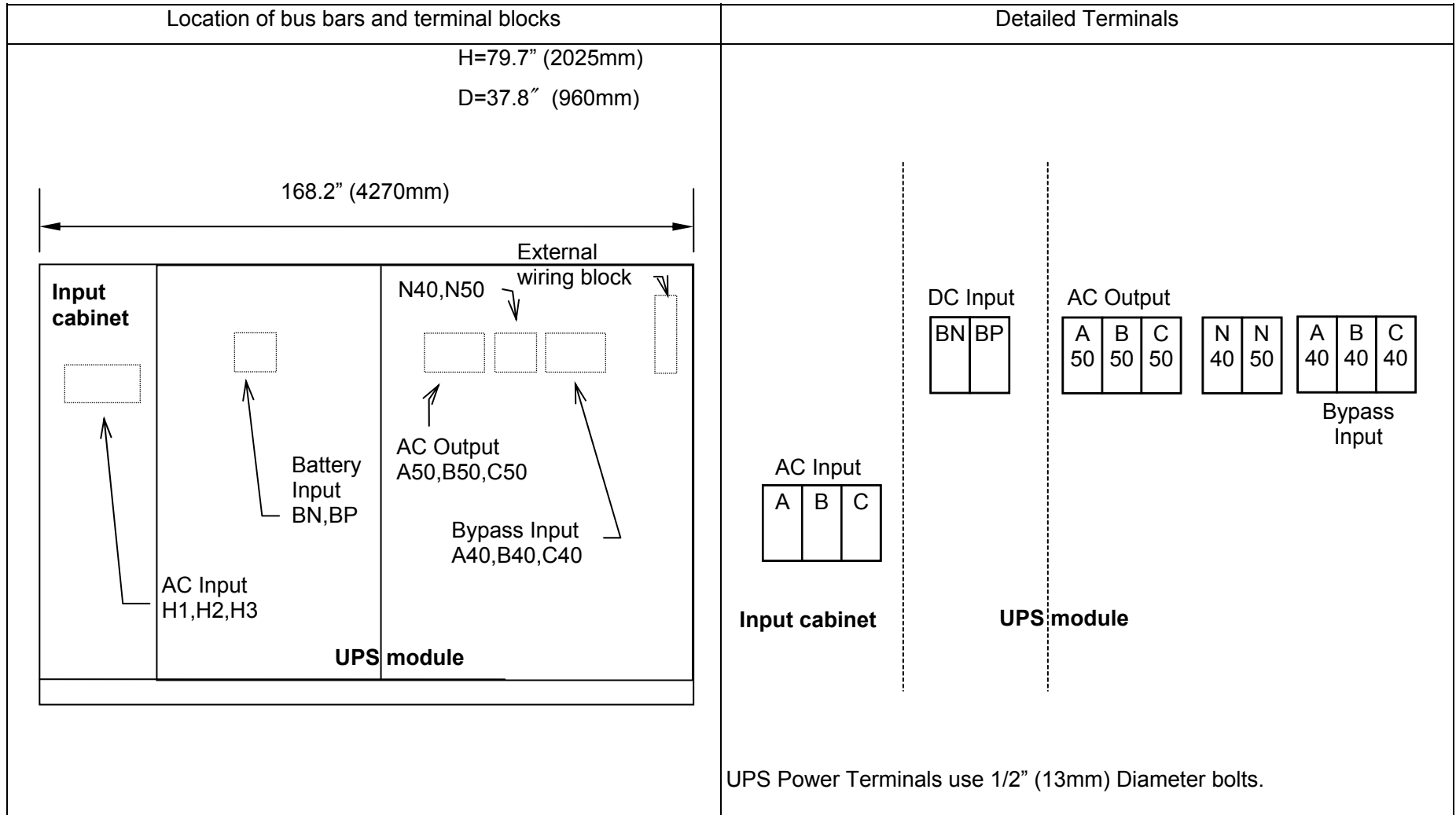

FIGURE 3.2-f-2 Diagram of Power Wire & Control Wire Inter-Connect (500kVA, 750kVA UPS, Input voltage 600Vac)

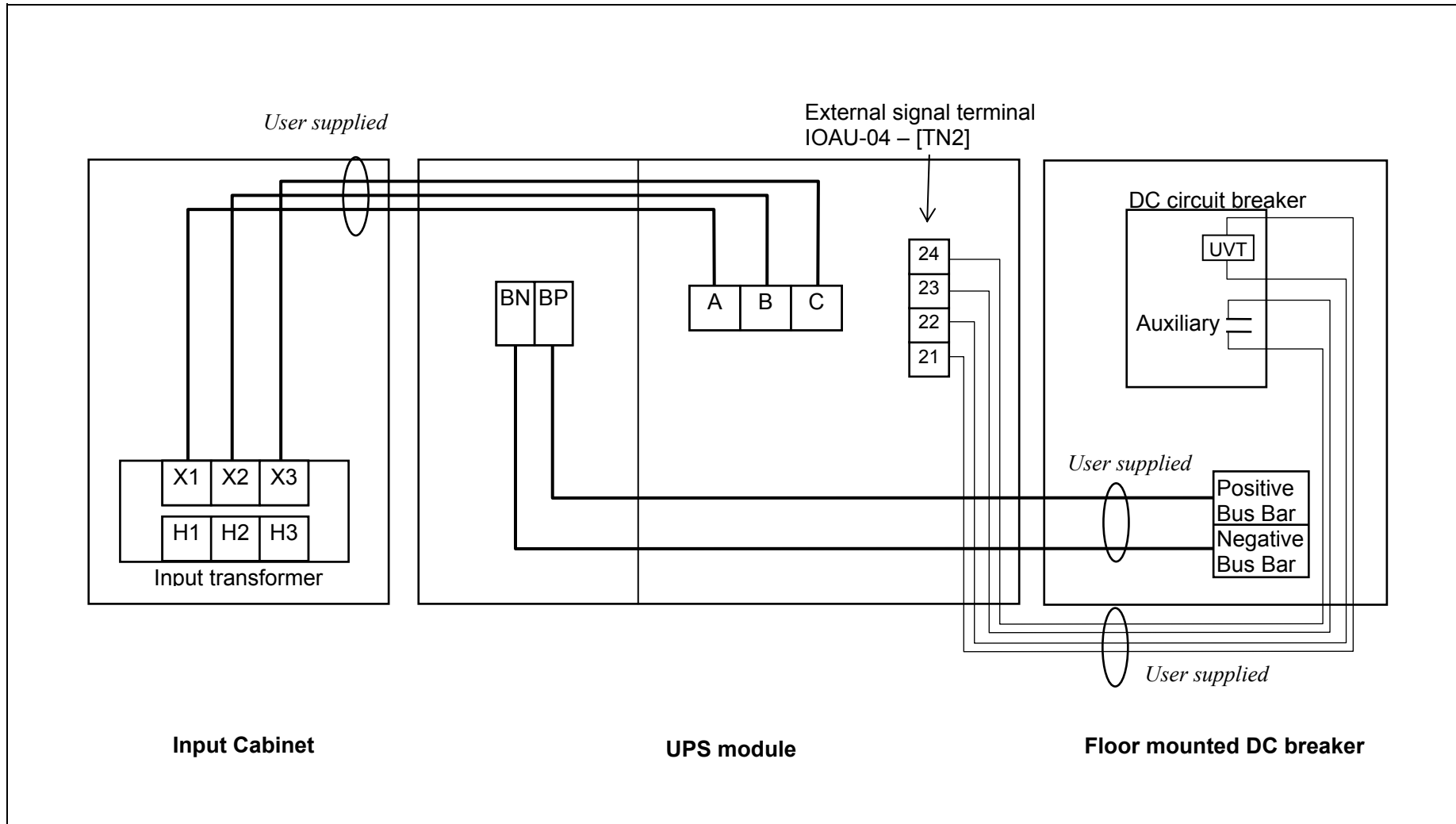

FIGURE 3.3-a Diagram of Rectifier Cabinet & Inverter Cabinet Inter-Connect 1 (500kVA, 750kVA UPS)



MITSUBISHI ELECTRIC 9800A SERIES UPS



FIGURE 3.3-b Diagram of Rectifier Cabinet & Inverter Cabinet Inter-Connect 2 (500kVA, 750kVA UPS)

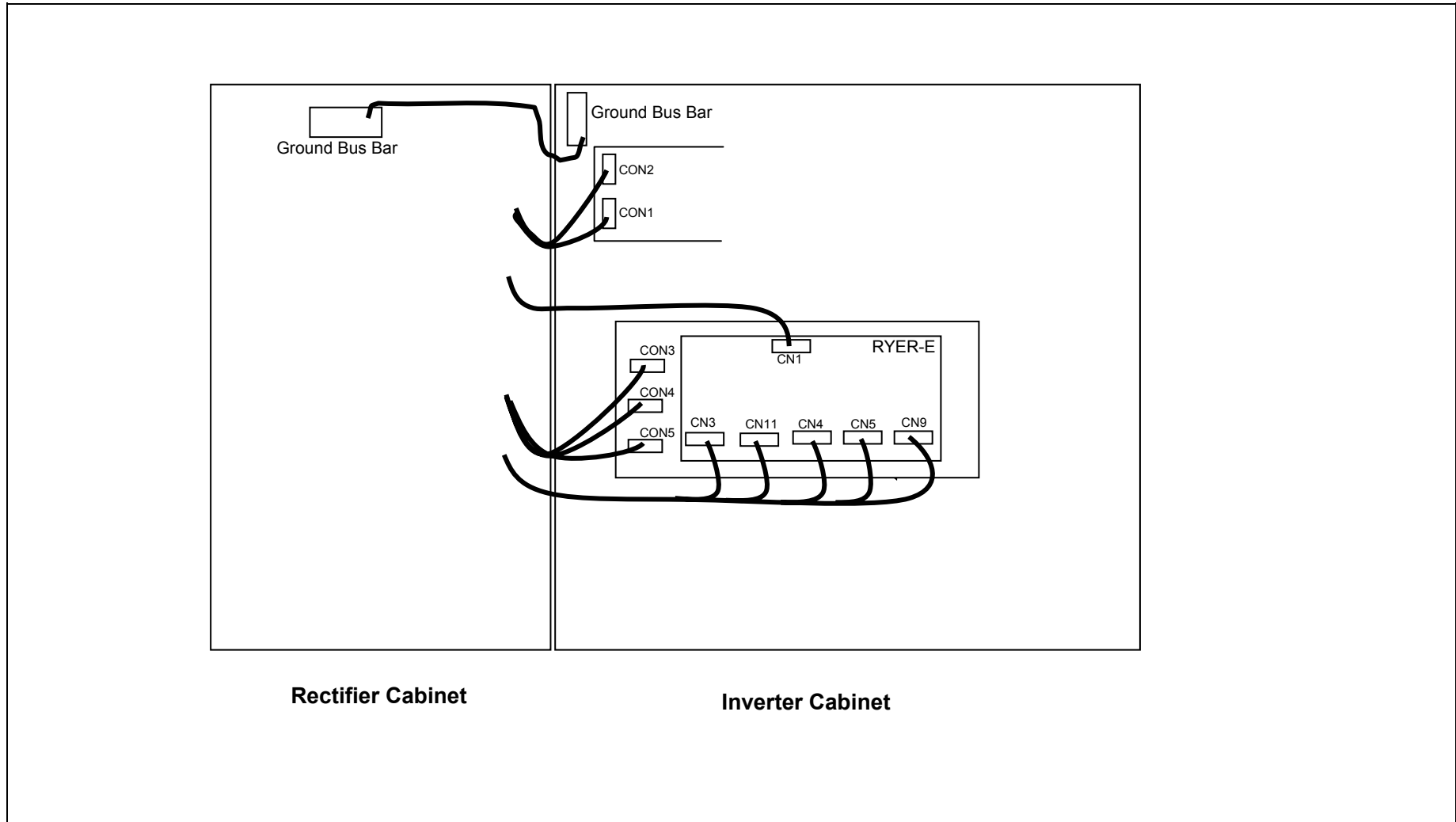
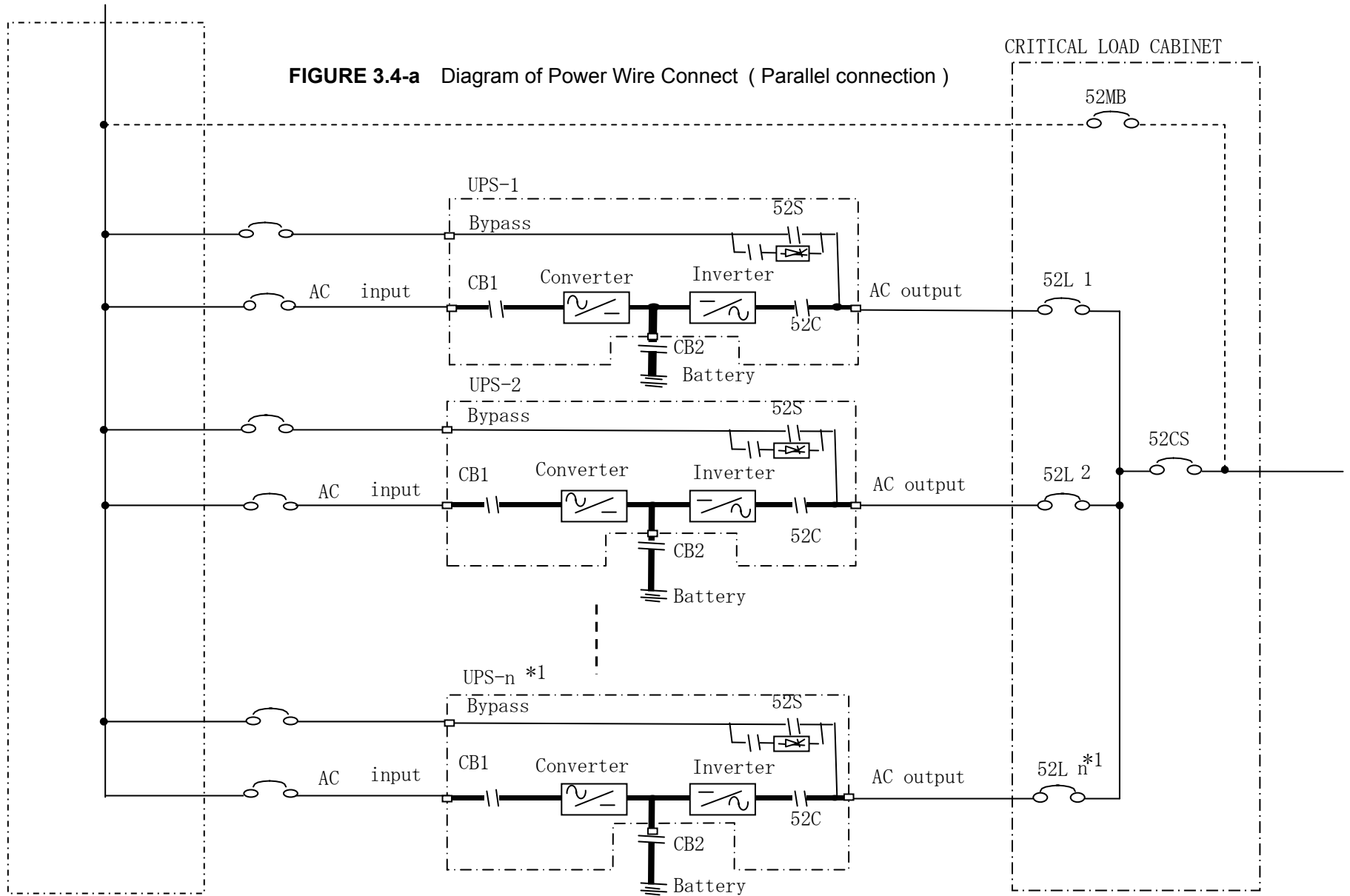

FIGURE 3.4-a Diagram of Power Wire Connect (Parallel connection)



*1 n : Maximum = 8

FIGURE 3.4-b Diagram of Power Wire & Control Wire Connect (Parallel connection)

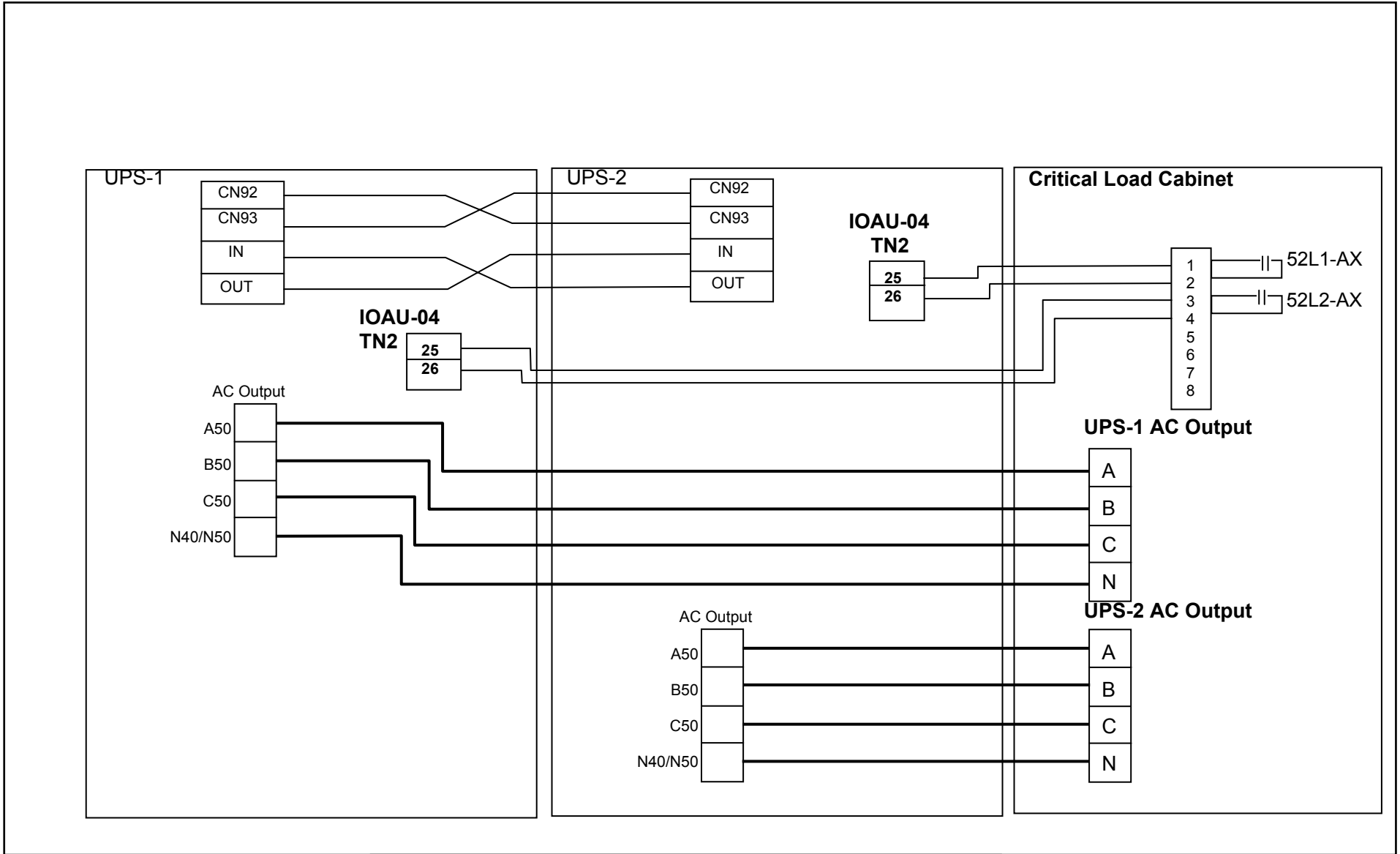
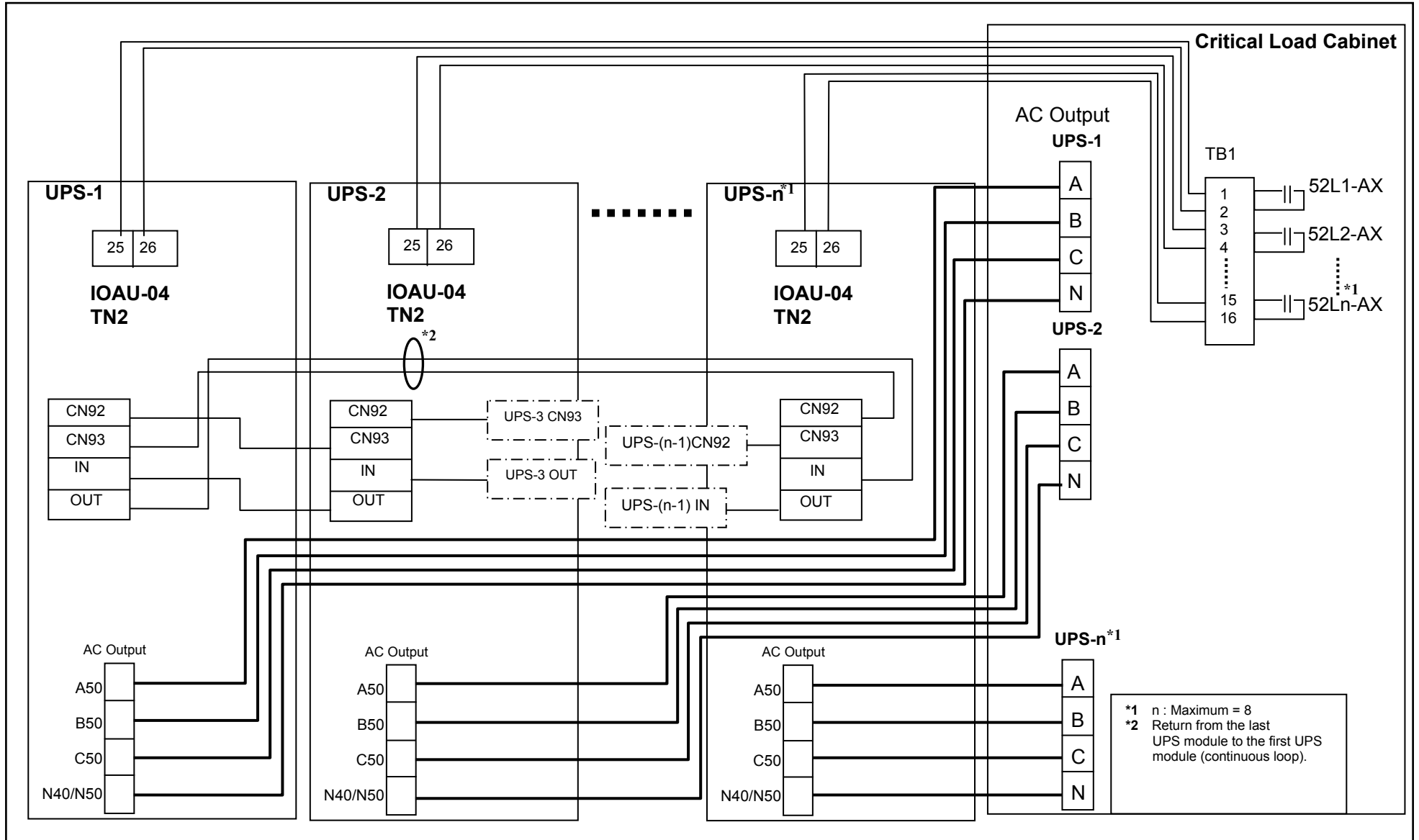

FIGURE 3.4-c Diagram of Power Wire & Control Wire Connect (Parallel connection)



3.4 Operating Procedures

A) Start-up Procedure

- Verify that Critical Load Cabinet (CLC) Circuit Breakers 52L1, 52L2...and 52Ln are closed.
- Verify that the External Bypass Input Circuit Breaker for each unit is closed (Breaker is user supplied.)
- If a dual source is feeding the UPS, close the External AC Rectifier Input Circuit Breaker manually (user supplied).

Start-up of UPS-1

- Verify that Control Circuit Breakers (CPM) is closed.
(When Inverter is stopped, the Control Circuit Breaker is not normally opened)
- The pre-charging cycle will begin and Input Contactor (CB1) will close automatically.
- Close Battery Disconnect Circuit Breaker (CB2).
- The inverter can now be started.



Note: When "REMOTE OPERATION MODE" is displayed on the LCD panel, the inverter start operation can only be performed remotely. If local inverter start operation is required (at the UPS), select "LOCAL" in "Remote/Local" selection in setup page. Select "LOCAL" mode for the purpose of this start up procedure.

- On the LCD panel, select "START/STOP MENU" and press the "START" key.
- The Inverter will start within 5 seconds. Start up is complete.

Start-up of next UPS

The next UPS can be started in the same way as UPS-1.

FIGURE 3.5-a Start-up Procedure

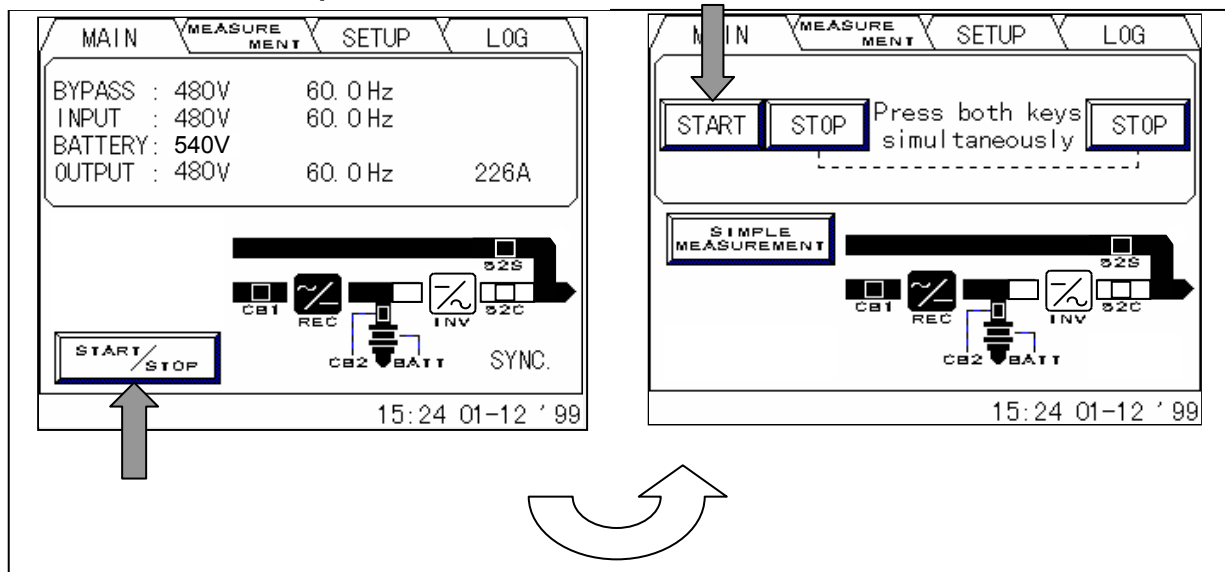

B) Shut-down Procedure

If a total UPS shutdown is required, verify that the critical load is OFF.

Shut-down of UPS-1

1. Press the "START/STOP MENU" from the Main Menu on the LCD.



Note: When "REMOTE OPERATION MODE" is displayed on the LCD panel, the inverter stop operation can only be performed remotely. If local inverter stop operation is required (at the UPS), select "LOCAL" in "Remote/Local" selection in setup page. Select "LOCAL" mode for the purpose of this stop procedure.

2. Press both "STOP" keys simultaneously on the LCD.
3. In general, only the Inverter will be stopped and the Rectifier will remain energized to charge the batteries.

Opening the user supplied External Input AC Circuit Breaker (if dual source used), the External Bypass Input Circuit Breaker and the DC Disconnect Circuit Breaker, CB2, will shut down the load.

4. If stopping both the Rectifier and Charger is required, open the Battery Disconnect circuit breaker (CB2) manually.
5. If a dual source is feeding the UPS, open the External AC Rectifier Input Circuit Breaker (user supplied) manually.
6. If turning off all power to the critical load is desired, open the External Bypass Input Circuit Breaker (user supplied) manually.

Shut-down of next UPS

The next UPS can be shut down in the same way as UPS-1.

The parallel UPS system will be in bypass operation when all inverters stops.

FIGURE 3.5-b Shut-down Procedure

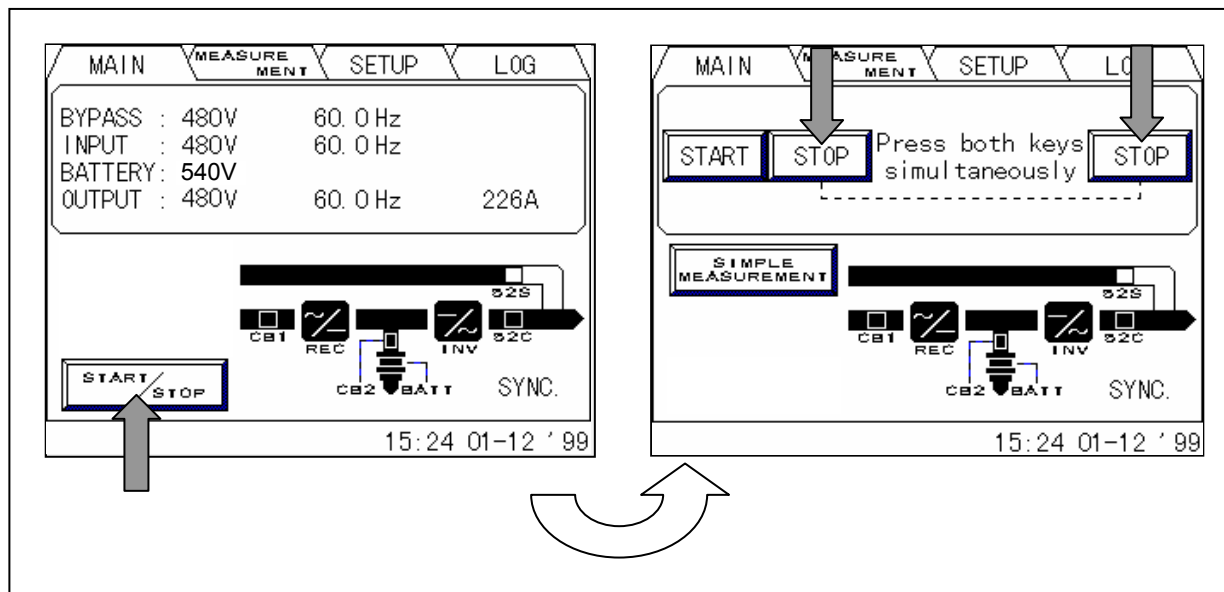

C) Bypass Operation Procedure

UPS-1

1. Check for "SYNC" on the LCD.
2. Press the "START/STOP MENU" from the LCD Main Menu.
3. Press the "STOP" key on the LCD.

Next UPS

Stop the next UPS in the same way as UPS-1.

The paralleling UPS system will be in bypass operation when all inverters stop.

** Transfer from bypass to inverter.

UPS-1

1. Press the "START/STOP MENU" from the LCD Main Menu.
2. Press the "START" key on the LCD.

Next UPS

Start the next UPS in the same way as UPS-1.

The paralleling UPS system will be in inverter operation when all inverters start.



Note: When "REMOTE OPERATION MODE" is displayed on the LCD panel, the inverter start or stop operation can only be performed remotely. If local inverter start or stop operation is required (at the UPS), select "LOCAL" in "Remote/Local" selection in setup page. Select "LOCAL" mode for the purpose of this stop procedure.

4.0 RESPONSE TO UPS FAILURE

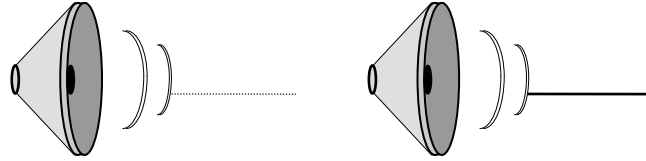
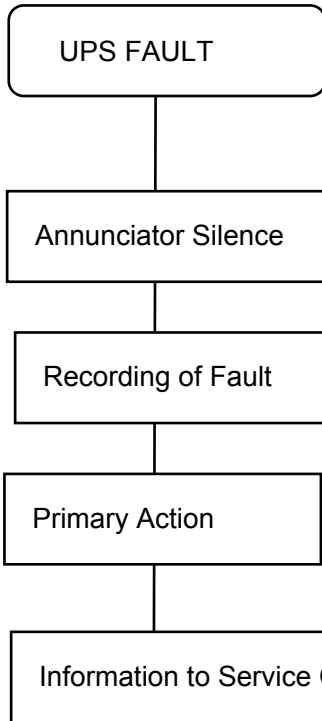

Depress "SILENCE ALARM" key on MAIN menu.

Refer to the list of fault codes in section 6.0 for error description.

Take necessary action according to display guidance.

When a faults occur, contact the Authorized Mitsubishi Service Representative or call Mitsubishi at **1-800-887-7830**.



Note

The error code indicated on the LCD display panel at the time of a UPS alarm condition is very important. In order to reduce repair time, please include this information, along with the operation status and load status for all correspondence with Mitsubishi's field service group.

5.0 PARTS REPLACEMENT

Contact Mitsubishi or its Authorized Service Center on all issues regarding the replacement of parts.

A) Battery

Battery lifetime may vary according to the frequency of use and the average ambient operating temperature. The end of battery life is defined as the state of charge resulting in an ampere-hour capacity less than, or equal to, 80% of nominal capacity.

Replace battery if its capacity is within this percentage.

B) UPS Component Parts

Contact Mitsubishi or its Authorized Service Center for a complete parts replacement schedule. Recommended replacement time interval varies with operating environment. Contact Mitsubishi or its Authorized Service Center for application specific recommendations.

6.0 FAULT CODES

This section covers fault codes, their description and required action.

At time of error :

- A) Verify and record the occurrence of the alarm. Note details of alarm message displayed on the LCD display panel.

Contact Mitsubishi Electric Automation, Inc. at 1-800-887-7830.

- B) If a circuit breaker (MCCB) has tripped, depress the toggle to reset the breaker before closing it again.

Failure Table 6.1 Fault Code

Code List

Note 9 Code indication	Status message	Contents	Guidance	Note 1 Buzzer	Note 2 External send-out contact	Note 3 Failure lamp
UF003	CONVERTER ABNORMAL	Preliminary charge impossible	CALL SERVICE ENGINEER	[2]	Major	Lit on
UF006	CONVERTER ABNORMAL	Mixed operation (60 minutes)	CALL SERVICE ENGINEER	[2]	Major	Lit on
UF055	CONVERTER ABNORMAL	Mixed operation (1 minute)	CALL SERVICE ENGINEER	[1]	Minor	Flicker
UF059	INPUT CIRCUIT ABNORMAL	Input circuit abnormality	CALL SERVICE ENGINEER	[1]	Minor	Flicker
UF102	DC OVERVOLTAGE	Over voltage of DC voltage	CALL SERVICE ENGINEER	[2]	Major	Lit on
UF103	DC UNDERVOLTAGE	Low voltage of DC voltage	CALL SERVICE ENGINEER	[2]	Major	Lit on
UF108	CHOPPER OVERCURRENT	Chopper output overcurrent	CALL SERVICE ENGINEER	[2]	Major	Lit on
UF151	DC VOLTAGE ABNORMAL	Does not return to float voltage after power supply is resumed (24 hours)	CALL SERVICE ENGINEER	[1]	Minor	Flicker
UF152	DC VOLTAGE ABNORMAL	Does not return to equalizing voltage after power supply is resumed	CALL SERVICE ENGINEER	[1]	Minor	Flicker
UF153	CB2 ABNORMAL	Battery disconnect circuit breaker CB2 has tripped.	CALL SERVICE ENGINEER	[1]	Minor	Flicker
UF156	CB2 TRIPPED(BATTERY OVERTEMP.)	Battery temperature abnormality (UF157) lasted a long time (Note 5)	CHECK BATTERY	[1]	Minor	Flicker
UF157	BATTERY OVERTEMPERATURE	Battery temperature abnormality	CHECK BATTERY	[1]	Minor Note 4	Flicker
UF161	CB2 TRIPPED(DC VOLT. ABNORMAL)	Does not return to float voltage after power supply is resumed (48 hours) (Note 5)	CALL SERVICE ENGINEER	[1]	Minor	Flicker
UF162	BATTERY ABNORMAL	Battery abnormal detected by battery self test.	CALL SERVICE ENGINEER	[1]	Minor	Flicker
UF163	BATTERY VOLTAGE ABNORMAL	Battery voltage abnormality	CALL SERVICE ENGINEER	[1]	Minor	Flicker
UF165	IGBT FAULT (CHOPPER)	IGBT module (Chopper) overcurrent	CALL SERVICE ENGINEER	[2]	Major	Lit on

UF166	IGBT FAULT (A)	IGBT module (A) overcurrent	CALL SERVICE ENGINEER	[2]	Major	Lit on
UF167	IGBT FAULT (B)	IGBT module (B) overcurrent	CALL SERVICE ENGINEER	[2]	Major	Lit on
UF168	IGBT FAULT (C)	IGBT module (C) overcurrent	CALL SERVICE ENGINEER	[2]	Major	Lit on
UF201	INVERTER OVERVOLTAGE	Output overvoltage during inverter power supply (+ 15%)	CALL SERVICE ENGINEER	[2]	Major	Lit on
UF202	INVERTER UNDERVOLTAGE	Output low voltage during inverter supply (-15%)	CALL SERVICE ENGINEER	[2]	Major	Lit on
UF203	INVERTER OVERCURRENT	Inverter output overcurrent	CALL SERVICE ENGINEER	[2]	Major	Lit on
UP204	OUTPUT CIRCUIT ABNORMAL	Cross current fell out of 30%	CALL SERVICE ENGINEER	[2]	Major	Lit on
UF209	52C ABNORMAL	52C not turned ON	CALL SERVICE ENGINEER	[2]	Major	Lit on
UF210	52C ABNORMAL	52C not turned OFF	CALL SERVICE ENGINEER	[2]	Major	Lit on
UF213	INV. OR CONV. OVERTEMPERATURE	Overheating of main circuit parts	CALL SERVICE ENGINEER	[2]	Major	Lit on
UF214	COOLING FAN ABNORMAL	Abnormality of cooling fan inside panel	CALL SERVICE ENGINEER	[2]	Major	Lit on
UF255	52C ABNORMAL	52C turned OFF during inverter power supply	CALL SERVICE ENGINEER	[1]	Minor	Flicker
UF256	OUTPUT VOLTAGE ABNORMAL	Inverter output voltage fell out of +/- 5%	CALL SERVICE ENGINEER	[1]	Minor	Flicker
UF257	52C ABNORMAL	52C not turned OFF when manual transfer	CALL SERVICE ENGINEER	[1]	Minor	Flicker
UF258	LOAD ABNORMAL	More than 4 overcurrents for 10 minutes	CHECK LOAD	[1]	Minor	Flicker
UF259	Output voltage bus abnormal	Inverter output voltage bus abnormality	CALL SERVICE ENGINEER	[1]	Minor	Flicker
UF260	LOAD SHORT	After UA810 occurred, Bypass Abnormal occurred within 1 second. (#1)	CHECK LOAD	[1]	Minor	Flicker
UF301	UPS CONTROL CIRCUIT ERROR	Control microcomputer abnormality	CALL SERVICE ENGINEER	[2]	Major	Lit on
UF302	UPS CONTROL CIRCUIT ERROR	Control microcomputer abnormality	CALL SERVICE ENGINEER	[2]	Major	Lit on
UF303	UPS CONTROL CIRCUIT ERROR	Control microcomputer abnormality	CALL SERVICE ENGINEER	[2]	Major	Lit on
UF304	UPS CONTROL CIRCUIT ERROR	Parallel control circuit abnormality	CALL SERVICE ENGINEER	[2]	Major	Lit on

UF305	UPS CONTROL CIRCUIT ERROR	Control clock abnormality	CALL SERVICE ENGINEER	[2]	Major	Lit on
UF306	UPS CONTROL CIRCUIT ERROR	Control power source circuit abnormality	CALL SERVICE ENGINEER	[2]	Major	Lit on
UF309	INVERTER VOLTAGE ABNORMAL	Inverter output voltage abnormality before inverter power supply	CALL SERVICE ENGINEER	[2]	Major	Lit on
UF352	CONTROL POWER SUPPLY ABNORMAL	Control circuit abnormality	CALL SERVICE ENGINEER	[1]	Minor	Flicker
UF402	52S ABNORMAL	52S not turned OFF, or 52S turned OFF without any command	CALL SERVICE ENGINEER	[2]	Major	Lit on
UF403	CB3 ABNORMAL	CB3 not turned OFF (#2)	CALL SERVICE ENGINEER	[2]	Major	Lit on
UF451	52S ABNORMAL	52S not turned ON, or 52S turned ON without any command when manual transfer	CALL SERVICE ENGINEER	[1]	Minor	Flicker
UF452	CB3 ABNORMAL	CB3 open	CALL SERVICE ENGINEER	[1]	Minor	Flicker
UF453	52L OPERATION ERR.	52L operated abnormality	CHECK 52L	[2]	Major	Lit on
UA801	AC INPUT VOLTAGE OUT OF RANGE	AC input voltage fell out of +/- 15% range	CHECK INPUT POWER SOURCE	[1]	Alarm	-
UA806	INVERTER OVERLOAD > 100%	Overload exceeded 105% (Note 7)	WARNING : DECREASE LOAD	[1]	Alarm	-
UA808	INVERTER OVERLOAD > 125%	Overload exceeded 125% (Note 7)	WARNING : DECREASE LOAD	[1]	Alarm	-
UA809	INVERTER OVERLOAD > 150%	Overload exceeded 150% (Note 7)	WARNING : DECREASE LOAD	[1]	Alarm	-
UA810	INVERTER OVERLOAD	Momentary over-current during Inverter power.	WARNING : DECREASE LOAD	[1]	Alarm	-
UA811	OVERLOAD TRANS.	Overload transfer	-	[1]	Alarm	
UA812	BYPASS VOLTAGE OUT OF RANGE	Bypass voltage fell out of +/- 20% range	CHECK BYPASS INPUT	[1]	Alarm	-
UA813	BYPASS PHASE ROTATION ERROR	Phase rotation is inverted when bypass voltage is normal	CHECK BYPASS INPUT	[1]	Alarm	-
UA814	BYPASS FREQUENCY OUT OF RANGE	Bypass frequency fell out of inverter synchronization follow-up range	CHECK BYPASS INPUT	[1]	Alarm	-

UA817	EMERGENCY STOP ACTIVATED	Emergency stop applied	-	-	Alarm	-
UA819	REMOTE START BUTTON ABNORMAL	There is an error with the remote start switch.	CALL SERVICE ENGINEER	[1]	Alarm	-
UA820	REMOTE STOP BUTTON ABNORMAL	There is an error with the remote stop switch.	CALL SERVICE ENGINEER	[1]	Alarm	-
UA824	CB2 OPEN	Battery disconnect circuit breaker CB2 turned OFF	TURN ON CB2	[1]	Alarm	-
UA831	EMERGENCY BYPASS SWITCH ON	Emergency bypass switch turned to <Emergency>	-	[1]	Alarm	-
UA834	BATTERY DEPLETED INV. STOPPED	DC voltage dropped below discharge end during inverter operation	-	-	Alarm	-
UA841	CONVERTER OPE. PROHIBITION	Converter operation interlock applied	-	-	Alarm	-
UA842	OUTPUT CIRCUIT ABNORMAL	Load bus voltage sensor abnormality	-	-	Alarm	-

#1: It has the possibility that output short-circuits.

#2: Check the CB3 and Bypass Thyristors.

(Note 1) Audible annunciator: [1] intermittent sound, [2] continuous sound.

(Note 2) 1) "Major" is defined as major failure. Inverter transferred to the static bypass line;
2) "Minor" is defined as a minor failure. UPS continues to operate normally, but cause of alarm must be identified;

(Note 3) Indicates one of two possible LED illumination patterns - continuously on (lit) or intermittent (flicker).

(Note 4) External send-out possible by option setting.

(Note 5) Trips the battery breaker CB2.

(Note 6) For other than sealed-type battery.

(Note 7) If the specified time elapses, will transfer to the bypass power supply.

(Note 8) Shows only when corresponding option settings are made.

(Note 9) Code indication means:

UA+++-----	Alarm
UF+++-----	Failure
U%0++-----	Rectifier circuit failure
U%1++-----	DC circuit failure
U%2++-----	Inverter circuit failure
U%3++-----	Control circuit failure
U%4++-----	Bypass system failure
U%8++-----	Alarm
U%+00 - U%+49 -----	Major failure
U%+50 - U%+99 -----	Minor failure

*) "+" denotes any numeral from 0 to 9

*) "%" denotes either "A" or "F"

7.0 Warranty & Out of warranty Service

The Mitsubishi Electric UPS Systems Group Service Department has many Authorized Service Centers placed strategically throughout the US, Canada and Latin America. For both in warranty and out of warranty service, please contact Mitsubishi Electric Automation, Inc. at (847) 478-2500. To register your UPS for warranty purposes, please complete the warranty registration form and fax it to the Mitsubishi Electric UPS Systems Group, Service Department fax line shown on the registration form. (Next page)

For warranty purposes, it is essential that any and all service work that may be required on your Mitsubishi brand UPS equipment is performed by a Mitsubishi Electric Authorized Service Center. The use of non-authorized service providers may void your warranty.

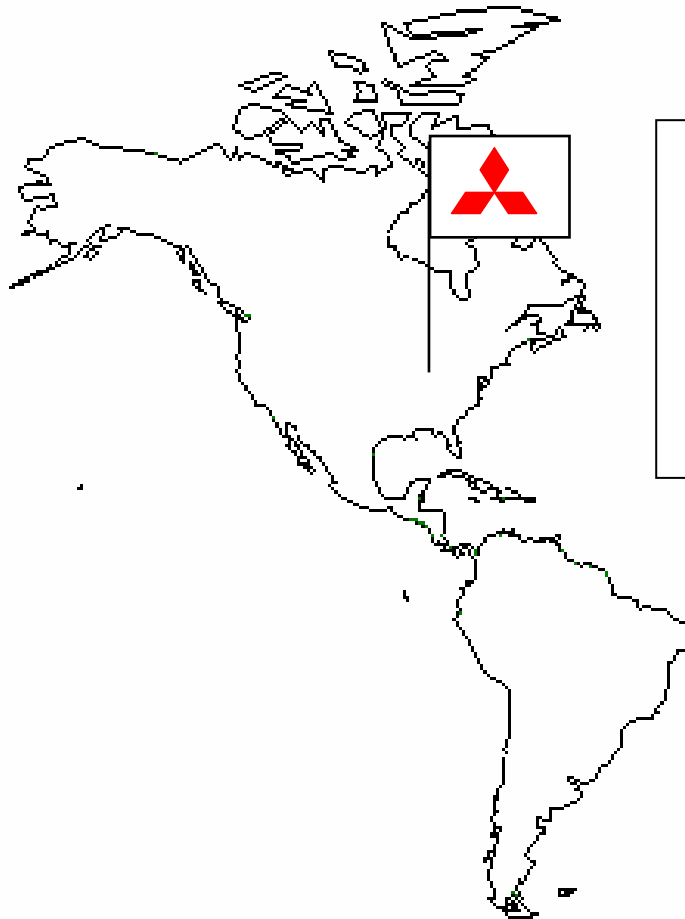

Mitsubishi Electric Automation Inc,
UPS Systems Group Service Department

500 Corporate Woods Parkway,
Vernon Hills, Illinois 60061, USA

Phone: (847) 478-2500

Fax: (847) 478-2290

Mitsubishi Electric Automation, Inc.
UNINTERRUPTIBLE POWER SUPPLIES

500 Corporate Woods Parkway, Vernon Hills, IL 60061 Phone: (847) 478-2643, Fax: (847) 478-2290

UPS Warranty Registration

 Register UPS for Warranty

 Address Change

To validate the Warranty on your UPS this form must be filled out completely by Customer and returned.

CUSTOMER INFORMATION		
Your Name:		Job Title:
Company Name:		
Division / Department:		
Address:		
City:	State:	Zip Code:
Country:		Province:
Business Phone:	Ext:	Fax:
E-Mail: _____ @ _____		Internet Address:
UPS Model #:	Capacity (kVA):	UPS Serial #:
Start-Up Date: / /	Authorized Mitsubishi Service Company (if known):	
Signature: _____		Date: / /

Which ONE of These Best Describes Your Organization's Primary Business Classification?
{Energy Producer}

-
- Utility
-
-
- Alternate Energy

{Manufacturing Co.}

-
- OEM
-
-
- Process

 Consumer Goods

-
- Electronics
-
-
- Power Quality Equipment

 Commercial Business
 Electrical Contractor
 Healthcare
 Internet
 Education/Univ. Service
{Service}

-
- Consulting
-
-
- Engineering
-
-
- Outsourcing
-
-
- Financial/Legal/Insurance
-
- {Expectations}**

{Government}

-
- Military
-
-
- Municipals
-
-
- Federal/State/Local

 Communications
 Distributors/Reps
 Other _____

Number of Employees at This Location is:

-
- 1 – 19
-
- 100 - 249
-
- 1000 or more
-
-
- 20 – 49
-
- 250 - 499
-
-
- 50 – 99
-
- 500 - 999

Overall how was Start-Up performed:

-
- Unsatisfactory
-
- Satisfactory
-
- Exceeded

Would you like to receive future product updates and news?

-
- Yes
-
- No

**After Start-Up has been done Fax completed Form to:
(847) 478-2290**